



KTA SPINDLE TOOLINGS

A Tool Holder Company

www.ktaspindletoolings.com











Check Stock @ Link
<http://119.81.67.54/CRMWebsite/ViewCurrentStockPosition.aspx>
And send enquiry to the nearest dealer.

2019









**Precision Tool Holders
BT - DIN ISO 7388 - 2
(MAS 403)**



INDEX

Sr. No.	Contents		Page No.
1	Technical Information: BT(MAS 403) DIN ISO 7388 - 2		5
2	Collet Chucks ER (DIN 6499) <ul style="list-style-type: none"> • Collet Chuck ER (AD) DIN ISO 7388 - 2 JD • Collet Chuck ER (AD+B) DIN ISO 7388 - 2 JD/JF • Collet Chuck ER "M" Type (AD+B) DIN ISO 7388 - 2 JD/JF • Collet Chuck ER "A" Type (Short GP) 		6 - 10
3	Weldon Type End Mill Holders (DIN 6359) <ul style="list-style-type: none"> • Weldon (WE) (AD) DIN ISO 7388 - 2 JD • Weldon (WE) FCC (AD+B) DIN ISO 7388 - 2 JD/JF 		11 - 16
4	Face Mill Holders (DIN 6357) <ul style="list-style-type: none"> • FMH (AD) DIN ISO 7388 - 2 JD • FMH-K (Through Coolant) (AD+B) DIN ISO 7388 - 2 JD/JF 		17 - 18
5	Combi Shell Mill Adaptor (CSMA) (DIN 6358)		19
6	Morse Taper Adaptor (MTA) (DIN 6383)		20
7	Reduction Sleeve (BT50 x BT40)		21
8	Boring Bar Blank		22
9	Master Mandrell		23
10	NC Drill Chuck (NCDC)		24

INDEX

Sr. No.	Contents		Page No.
11	Die & Mould Chuck (DMC)		25 - 26
12	Power Milling Chuck (PMC)		27 - 28
13	Milling Cutter Arbor (MCA)		29 - 31
14	Shrink Fit Holders 4.5 Degree (SFH 4.5°) <ul style="list-style-type: none"> • Shrink Fit Holder (SFH 4.5°) (AD) DIN ISO 7388 - 2 JD • Shrink Fit Holder (SFH 4.5°) (AD+B) DIN ISO 7388 - 2 JD/JF • Shrink Fit Holder (SFH FCC 4.5°) (AD) DIN ISO 7388 - 2 JD (Face Coolant Channel) • Shrink Fit Holder (SFH FCC 4.5°) (AD+B) DIN ISO 7388 - 2 JD/JF (Face Coolant Channel) 	 	32 - 42
15	Shrink Fit Holders Slim 3 Degree (SFH Slim 3°) <ul style="list-style-type: none"> • Shrink Fit Holder (SFH Slim 3°) (AD) DIN ISO 7388 - 2 JD • Shrink Fit Holder (SFH Slim 3°) (AD+B) DIN ISO 7388 - 2 JD/JF 		43 - 45
16	Hydraulic Expansion Chuck (HC)		46 - 47
17	Minimum Length Compensation Tapping Chuck (MLC)		48 - 49
18	Quick Change Tapping Chuck (KWFLK)		50 - 51

BT (MAS 403) Form A

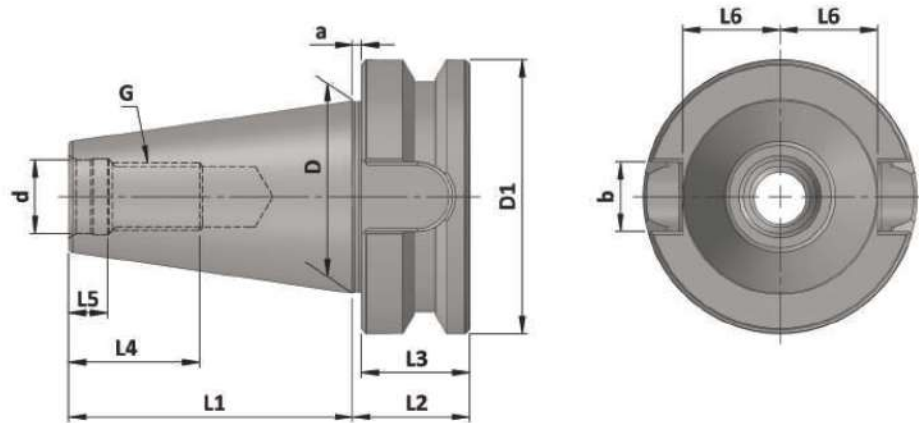

BT (MAS 403)
DIN ISO 7388 - 2
Holders

ISO	d	d1	D	D1	a	b	e1	G	L1	L2	L3	L4	L5	L6
30	12.5	-	31.75	46	2	16.1	-	M12	48.4	22	20	24	7.0	16.3
40	17	M4	44.45	63	2	16.1	27	M16	65.4	27	25	32	9.0	22.6
50	25	M6	69.85	100	3	25.7	42	M24	101.8	38	35	47	13.0	35.4

Old Name : BT (MAS 403) Form AD
New Name : BT (MAS 403) DIN ISO7388 - 2 JD
(Coolant Supply Through Center)

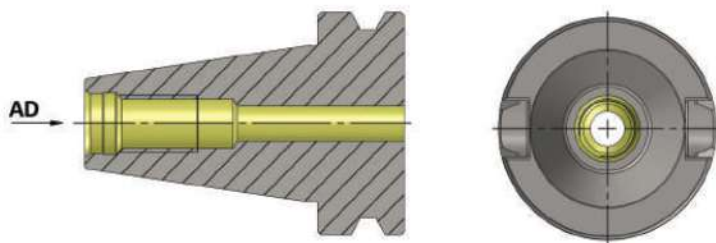

Old Name : BT (MAS 403) Form AD+B
New Name : BT (MAS 403) DIN ISO7388 - 2 JD/JF
(Coolant Supply Through Flange)

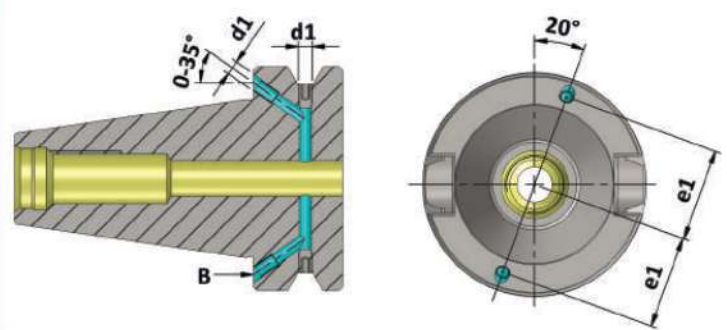

Material :- Case hardened steel, tensile strength in the core min. 950 N/mm²
Execution :- Case hardened to HRC 58 ± 2, Case Depth 0.8 mm., Silver finish.
Accuracy :- 7:24 Taper Angle Class AT 3 As per DIN 2080

Taper Class AT 3 Details

ISO	L	DA-DB	AT 3
30	42	12.280	+0.002
40	59	17.208	+0.003
50	92	26.833	+0.004

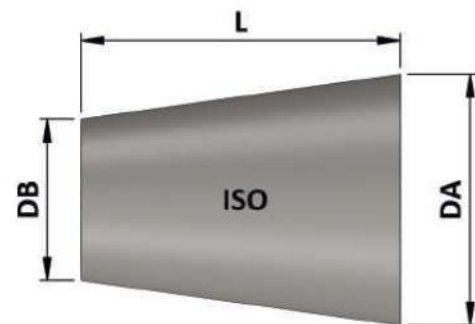

Note: All Dimensions are in mm

Maximum Run out of the Internal Taper with respect to the External Taper 0.005 mm

BT (MAS 403)
DIN ISO 7388 - 2
Holders

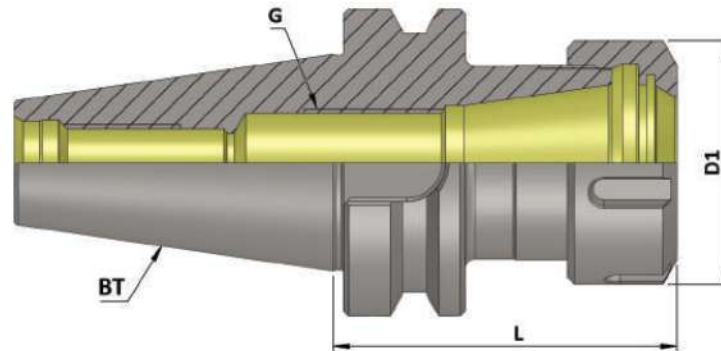

**(Balanced to 6.3 G 15000 RPM) /
(Balanced to 2.5 G 25000 RPM)**

BT (MAS 403) Collet Chuck ER (AD) (JD)

Item Name	Item Code	ISO	Suitable Collet	Collet Capacity	D1	G	L	Nut	Spanner
BT 30 ER 16 060 AD/6.3G15000 SL	K10101149117110	30	ER 16	0.5-10	32	M10X1	60	UM/ER16	E16
BT 30 ER 16 100 AD/6.3G15000 SL	K10101149148110	30	ER 16	0.5-10	32	M10X1	100	UM/ER16	E16
BT 30 ER 20 060 AD/6.3G15000 SL	K10101150117110	30	ER 20	1.0-13	35	M10X1	60	UM/ER20	E20
BT 30 ER 20 100 AD/6.3G15000 SL	K10101150148110	30	ER 20	1.0-13	35	M10X1	100	UM/ER20	E20
BT 30 ER 25 060 AD/6.3G15000 SL	K10101151117110	30	ER 25	1.0-16	42	M18X1	60	UM/ER25	E25
BT 30 ER 25 100 AD/6.3G15000 SL	K10101151148110	30	ER 25	1.0-16	42	M18X1	100	UM/ER25	E25
BT 30 ER 32 060 AD/6.3G15000 SL	K10101152117110	30	ER 32	2.0-20	50	M22X1.5	60	UM/ER32	E32
BT 30 ER 32 100 AD/6.3G15000 SL	K10101152148110	30	ER 32	2.0-20	50	M22X1.5	100	UM/ER32	E32
BT 30 ER 40 080 AD/6.3G15000 SL	K10101153131110	30	ER 40	3.0-26	63	M30X1.5	80	UM/ER40	E40
BT 30 ER 32 050 AD/2.5G25000SL	K10101152111228	30	ER 32	2.0-20	50	M22X1.5	50	UM/ER32	E32
BT 40 ER 16 070 AD/6.3G15000 SL	K10102149125110	40	ER 16	0.5-10	32	M10X1	70	UM/ER16	E16
BT 40 ER 16 100 AD/6.3G15000 SL	K10102149148110	40	ER 16	0.5-10	32	M10X1	100	UM/ER16	E16
BT 40 ER 16 160 AD/6.3G15000 SL	K10102149175110	40	ER 16	0.5-10	32	M10X1	160	UM/ER16	E16
BT 40 ER 20 070 AD/6.3G15000 SL	K10102150125110	40	ER 20	1.0-13	35	M10X1	70	UM/ER20	E20
BT 40 ER 20 100 AD/6.3G15000 SL	K10102150148110	40	ER 20	1.0-13	35	M10X1	100	UM/ER20	E20
BT 40 ER 20 160 AD/6.3G15000 SL	K10102150175110	40	ER 20	1.0-13	35	M10X1	160	UM/ER20	E20
BT 40 ER 25 070 AD/6.3G15000 SL	K10102151125110	40	ER 25	1.0-16	42	M18X1	70	UM/ER25	E25
BT 40 ER 25 100 AD/6.3G15000 SL	K10102151148110	40	ER 25	1.0-16	42	M18X1	100	UM/ER25	E25
BT 40 ER 25 160 AD/6.3G15000 SL	K10102151175110	40	ER 25	1.0-16	42	M18X1	160	UM/ER25	E25
BT 40 ER 32 070 AD/6.3G15000 SL	K10102152125110	40	ER 32	2.0-20	50	M22X1.5	70	UM/ER32	E32
BT 40 ER 32 100 AD/6.3G15000 SL	K10102152148110	40	ER 32	2.0-20	50	M22X1.5	100	UM/ER32	E32
BT 40 ER 32 160 AD/6.3G15000 SL	K10102152175110	40	ER 32	2.0-20	50	M22X1.5	160	UM/ER32	E32
BT 40 ER 40 070 AD/6.3G15000 SL	K10102153125110	40	ER 40	3.0-26	63	M30X1.5	70	UM/ER40	E40
BT 40 ER 40 100 AD/6.3G15000 SL	K10102153148110	40	ER 40	3.0-26	63	M30X1.5	100	UM/ER40	E40
BT 40 ER 40 160 AD/6.3G15000 SL	K10102153175110	40	ER 40	3.0-26	63	M30X1.5	160	UM/ER40	E40
BT 40 ER 50 100 AD/6.3G15000 SL	K10102154148110	40	ER 50	10.0-34	78	M16X2	100	UM/ER50	E50

Note: All Dimensions are in mm

Maximum Run out of the Internal Taper with respect to the External Taper 0.005 mm

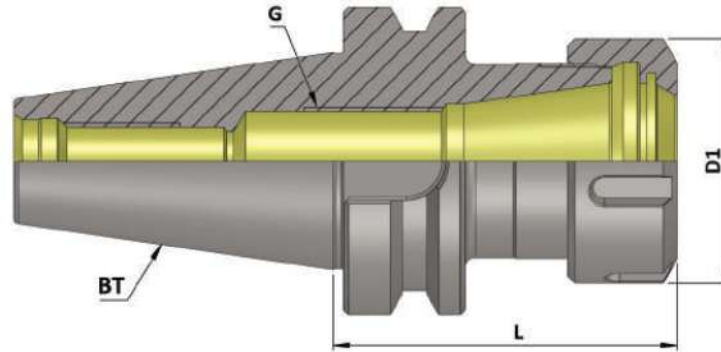

BT (MAS 403)
DIN ISO 7388 - 2
Holders

BT (MAS 403) Collet Chuck ER (AD) (JD)

(Balanced to 6.3 G 15000 RPM)

Item Name	Item Code	ISO	Suitable Collet	Collet Capacity	D1	G	L	Nut	Spanner
BT50 ER 16 080 AD/6.3G15000 SL	K10103149131110	50	ER 16	0.5-10	32	M10X1	80	UM/ER16	E16
BT50 ER 16 100 AD/6.3G15000 SL	K10103149148110	50	ER 16	0.5-10	32	M10X1	100	UM/ER16	E16
BT50 ER 16 160 AD/6.3G15000 SL	K10103149175110	50	ER 16	0.5-10	32	M10X1	160	UM/ER16	E16
BT50 ER 20 100 AD/6.3G15000 SL	K10103150148110	50	ER 20	1.0-13	35	M10X1	100	UM/ER20	E20
BT50 ER 20 160 AD/6.3G15000 SL	K10103150175110	50	ER 20	1.0-13	35	M10X1	160	UM/ER20	E20
BT50 ER 25 080 AD/6.3G15000 SL	K10103151131110	50	ER 25	1.0-16	42	M18X1	80	UM/ER25	E25
BT50 ER 25 100 AD/6.3G15000 SL	K10103151148110	50	ER 25	1.0-16	42	M18X1	100	UM/ER25	E25
BT50 ER 25 160 AD/6.3G15000 SL	K10103151175110	50	ER 25	1.0-16	42	M18X1	160	UM/ER25	E25
BT50 ER 32 080 AD/6.3G15000 SL	K10103152131110	50	ER 32	2.0-20	50	M22X1.5	80	UM/ER32	E32
BT50 ER 32 100 AD/6.3G15000 SL	K10103152148110	50	ER 32	2.0-20	50	M22X1.5	100	UM/ER32	E32
BT50 ER 32 160 AD/6.3G15000 SL	K10103152175110	50	ER 32	2.0-20	50	M22X1.5	160	UM/ER32	E32
BT50 ER 40 080 AD/6.3G15000 SL	K10103153131110	50	ER 40	3.0-26	63	M30X1.5	80	UM/ER40	E40
BT50 ER 40 100 AD/6.3G15000 SL	K10103153148110	50	ER 40	3.0-26	63	M30X1.5	100	UM/ER40	E40
BT50 ER 40 160 AD/6.3G15000 SL	K10103153175110	50	ER 40	3.0-26	63	M30X1.5	160	UM/ER40	E40
BT50 ER 50 100 AD/6.3G15000 SL	K10103154148110	50	ER 50	10.0-34	78	M16X2	100	UM/ER50	E50
BT50 ER 50 160 AD/6.3G15000 SL	K10103154175110	50	ER 50	10.0-34	78	M16X2	160	UM/ER50	E50

Accessories:



Collet ER (DIN 6499)
Ref. Page No. 233-237



Q.C.Tap Collet QCTC
Ref. Page No. 243-251



ER Nut
Ref. Page No. 220-221

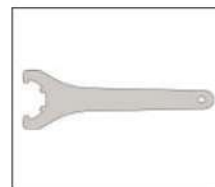

ER Spanner
Ref. Page No. 222

Note: All Dimensions are in mm

Maximum Run out of the Internal Taper with respect to the External Taper 0.005 mm

BT (MAS 403)
DIN ISO 7388 - 2
Holders

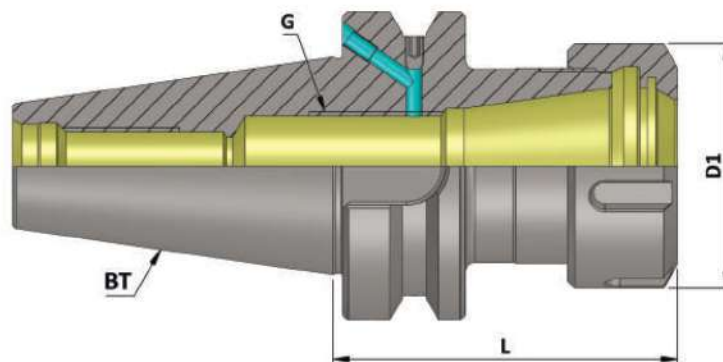

BT (MAS 403) Collet Chuck ER (AD+B) (JD/JF)

(Balanced to 6.3 G 15000 RPM)

Item Name	Item Code	ISO	Suitable Collet	Collet Capacity	D1	G	L	Nut	Spanner
BT40 ER 16 070 AD+B/6.3G15000SL	K10102149125112	40	ER 16	0.5-10	32	M10X1	70	UM/ER16	E16
BT40 ER 16 100 AD+B/6.3G15000SL	K10102149148112	40	ER 16	0.5-10	32	M10X1	100	UM/ER16	E16
BT40 ER 16 160 AD+B/6.3G15000SL	K10102149175112	40	ER 16	0.5-10	32	M10X1	160	UM/ER16	E16
BT40 ER 20 070 AD+B/6.3G15000 SL	K10102150125112	40	ER 20	1.0-13	35	M10X1	70	UM/ER20	E20
BT40 ER 20 100 AD+B/6.3G15000 SL	K10102150148112	40	ER 20	1.0-13	35	M10X1	100	UM/ER20	E20
BT40 ER 20 160 AD+B/6.3G15000 SL	K10102150175112	40	ER 20	1.0-13	35	M10X1	160	UM/ER20	E20
BT40 ER 25 070 AD+B/6.3G15000 SL	K10102151125112	40	ER 25	1.0-16	42	M18X1	70	UM/ER25	E25
BT40 ER 25 100 AD+B/6.3G15000 SL	K10102151148112	40	ER 25	1.0-16	42	M18X1	100	UM/ER25	E25
BT40 ER 25 160 AD+B/6.3G15000 SL	K10102151175112	40	ER 25	1.0-16	42	M18X1	160	UM/ER25	E25
BT40 ER 32 070 AD+B/6.3G15000 SL	K10102152125112	40	ER 32	2.0-20	50	M22X1.5	70	UM/ER32	E32
BT40 ER 32 100 AD+B/6.3G15000 SL	K10102152148112	40	ER 32	2.0-20	50	M22X1.5	100	UM/ER32	E32
BT40 ER 32 160 AD+B/6.3G15000 SL	K10102152175112	40	ER 32	2.0-20	50	M22X1.5	160	UM/ER32	E32
BT40 ER 40 070 AD+B/6.3G15000 SL	K10102153125112	40	ER 40	3.0-26	63	M30X1.5	70	UM/ER40	E40
BT40 ER 40 100 AD+B/6.3G15000 SL	K10102153148112	40	ER 40	3.0-26	63	M30X1.5	100	UM/ER40	E40
BT40 ER 40 160 AD+B/6.3G15000 SL	K10102153175112	40	ER 40	3.0-26	63	M30X1.5	160	UM/ER40	E40
BT40 ER 50 100 AD+B/6.3G15000 SL	K10102154148112	40	ER 50	10.0-34	78	M16X2	100	UM/ER50	E50
BT 50 ER 16 080 AD+B/6.3G 15000 SL	K10103149131233	50	ER 16	0.5-10	32	M10X1	80	UM/ER16	E16
BT 50 ER 16 100 AD+B/6.3G 15000 SL	K10103149148112	50	ER 16	0.5-10	32	M10X1	100	UM/ER16	E16
BT 50 ER 16 160 AD+B/6.3G 15000 SL	K10103149175112	50	ER 16	0.5-10	32	M10X1	160	UM/ER16	E16
BT 50 ER 25 080 AD+B/6.3G 15000 SL	K10103151131112	50	ER 25	1.0-16	42	M18X1	80	UM/ER25	E25
BT 50 ER 25 100 AD+B/6.3G 15000 SL	K10103151148112	50	ER 25	1.0-16	42	M18X1	100	UM/ER25	E25
BT 50 ER 25 160 AD+B/6.3G 15000 SL	K10103151175112	50	ER 25	1.0-16	42	M18X1	160	UM/ER25	E25
BT 50 ER 32 080 AD+B/6.3G 15000 SL	K10103152131112	50	ER 32	2.0-20	50	M22X1.5	80	UM/ER32	E32
BT 50 ER 32 100 AD+B/6.3G 15000 SL	K10103152148112	50	ER 32	2.0-20	50	M22X1.5	100	UM/ER32	E32
BT 50 ER 32 160 AD+B/6.3G 15000 SL	K10103152175112	50	ER 32	2.0-20	50	M22X1.5	160	UM/ER32	E32
BT 50 ER 40 080 AD+B/6.3G 15000 SL	K10103153131112	50	ER 40	3.0-26	63	M30X1.5	80	UM/ER40	E40
BT 50 ER 40 100 AD+B/6.3G 15000 SL	K10103153148112	50	ER 40	3.0-26	63	M30X1.5	100	UM/ER40	E40
BT 50 ER 40 160 AD+B/6.3G 15000 SL	K10103153175112	50	ER 40	3.0-26	63	M30X1.5	160	UM/ER40	E40
BT 50 ER 50 100 AD+B/6.3G 15000 SL	K10103154148112	50	ER 50	10.0-34	78	M16X2	100	UM/ER50	E50
BT 50 ER 50 160 AD+B/6.3G 15000 SL	K10103154175112	50	ER 50	10.0-34	78	M16X2	160	UM/ER50	E50

Note: All Dimensions are in mm

Maximum Run out of the Internal Taper with respect to the External Taper 0.005 mm

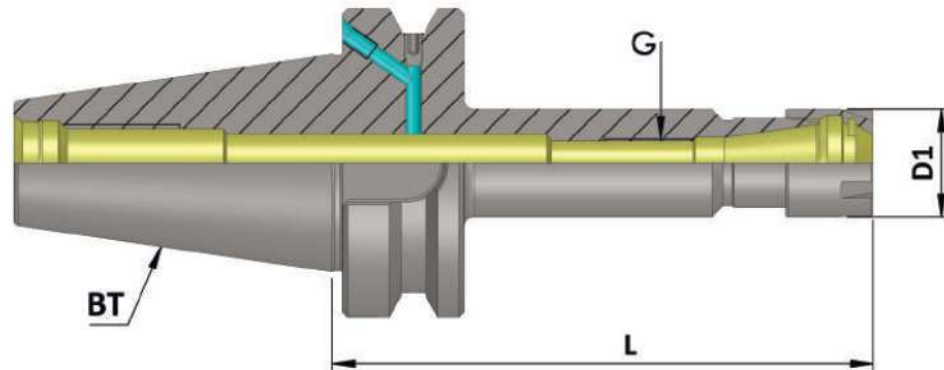

BT (MAS 403)
DIN ISO 7388 - 2
Holders

BT (MAS 403) Collet Chuck ER-M Type (AD+B) (JD/JF)

(Balanced to 2.5 G 25000 RPM)

Item Name	Item Code	ISO	Suitable Collet	Collet Capacity	D1	G	L	Nut	Spanner
BT 40 ER11M 070 AD+B/2.5G 25000 SL	K10102156125230	40	ER 11	0.5-7	16	M6X1	70	ER11M	E11M
BT 40 ER11M 100 AD+B/2.5G 25000 SL	K10102156148230	40	ER 11	0.5-7	16	M6X1	100	ER11M	E11M
BT 40 ER11M 160 AD+B/2.5G 25000 SL	K10102156175230	40	ER 11	0.5-7	16	M6X1	160	ER11M	E11M
BT 40 ER16M 070 AD+B/2.5G 25000 SL	K10102157125230	40	ER 16	0.5-10	22	M10X1	70	ER16M	E16M
BT 40 ER16M 100 AD+B/2.5G 25000 SL	K10102157148230	40	ER 16	0.5-10	22	M10X1	100	ER16M	E16M
BT 40 ER16M 120 AD+B/2.5G 25000 SL	K10102157162112	40	ER 16	0.5-10	22	M10X1	120	ER16M	E16M
BT 40 ER16M 160 AD+B/2.5G 25000 SL	K10102157175112	40	ER 16	0.5-10	22	M10X1	160	ER16M	E16M
BT 40 ER20M 120 AD+B/2.5G 25000 SL	K10102158162112	40	ER 20	1.0-13	28	M10X1	120	ER20M	E20M
BT 40 ER20M 160 AD+B/2.5G 25000 SL	K10102158175112	40	ER 20	1.0-13	28	M10X1	160	ER20M	E20M
BT 40 ER25M 070 AD+B/2.5G 25000 SL	K10102159125230	40	ER 25	1.0-16	35	M18X1	70	ER25M	E25M
BT 40 ER25M 100 AD+B/2.5G 25000 SL	K10102159148230	40	ER 25	1.0-16	35	M18X1	100	ER25M	E25M
BT 40 ER25M 120 AD+B/2.5G 25000 SL	K10102159162112	40	ER 25	1.0-16	35	M18X1	120	ER25M	E25M
BT 40 ER25M 160 AD+B/2.5G 25000 SL	K10102159175112	40	ER 25	1.0-16	35	M18X1	160	ER25M	E25M

Accessories:



Collet ER (DIN 6499)
Ref. Page No. 233-237



Tap Collet ER-G
Ref. Page No. 238-240



Q.C.Tap Collet QCTC
Ref. Page No. 243-251



ER Nut & ER Sealed Nut & ER M Nut
Ref. Page No. 220-221
& 224-225



Sealing Disc
Ref. Page No. 226-231



ER Spanner
Ref. Page No. 222

Note: All Dimensions are in mm

Maximum Run out of the Internal Taper with respect to the External Taper 0.005 mm

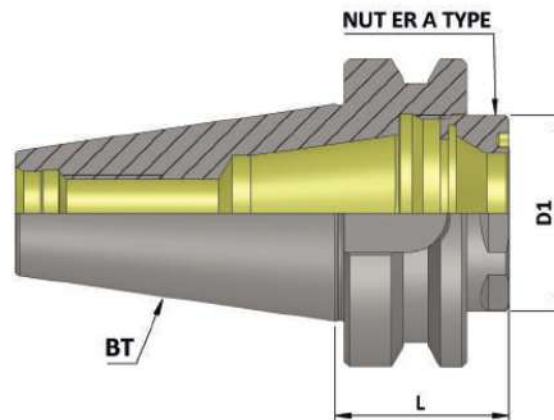

BT (MAS 403)
DIN ISO 7388 - 2
Holders

**(Balanced to 2.5 G 25000 RPM) /
(Balanced to 6.3 G 15000 RPM)**

BT (MAS 403) Short Length Collet Chuck ER - A

Item Name	Item Code	ISO	Suitable Collet	Collet Capacity	D1	L	Suitable Nut
BT 30 ER 25A 027AD/2.5G 25000 SL	K10101151500228	30	ER 25	1-16	32	27	ER25A
BT 40 ER 32A 32 AD/6.3G 15000 SL	K10102244248110	40	ER 32	2-20	40	32	ER32A
BT 50 ER 32A 43 AD/6.3G 15000 SL	K10103244249110	50	ER 32	2-20	40	43	ER32A

Accessories:



Collet ER (DIN 6499)
Ref. Page No. 233-237



Tap Collet ER-G
Ref. Page No. 238-240



Q.C.Tap Collet QCTC
Ref. Page No. 243-251



ER A Nut
Ref. Page No. 220-221

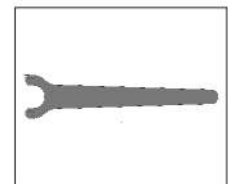

ER A Type Spanner
Ref. Page No. 222

Note: All Dimensions are in mm

Maximum Run out of the Internal Dia with respect to the External Taper 0.005 mm

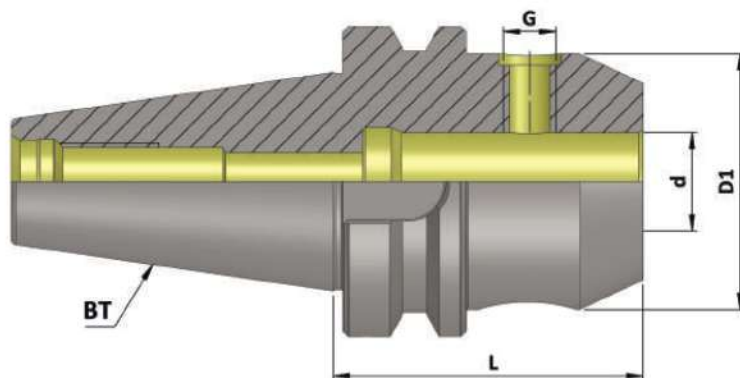

BT (MAS 403)
DIN ISO 7388 - 2
Holders

BT (MAS 403) (WE) (AD) (JD)

(Balanced to 6.3 G 15000 RPM)

Item Name	Item Code	ISO	d	D1	G	L	Screw Qty.
BT 30 WE06 050 AD/6.3G 15000SL	K10101111111110	30	6	25	M6	50	1
BT 30 WE08 050 AD/6.3G 15000 SL	K10101112111110	30	8	28	M8	50	1
BT 30 WE10 050 AD/6.3G 15000 SL	K10101113111110	30	10	35	M10	50	1
BT 30 WE12 055 AD/6.3G 15000 SL	K10101114115110	30	12	42	M12	55	1
BT 30 WE14 055 AD/6.3G 15000 SL	K10101258115110	30	14	44	M12	55	1
BT 30 WE16 063 AD/6.3G 15000 SL	K10101115119110	30	16	48	M14	63	1
BT 30WE18 063 AD/6.3G 15000 SL	K10101259119110	30	18	50	M14	63	1
BT 30WE20 070 AD/6.3G 15000 SL	K10101116125110	30	20	52	M16	70	1

BT 40WE06 050 AD/6.3G 15000 SL	K10102111111110	40	6	25	M6	50	1
BT 40WE06 100 AD/6.3G 15000 SL	K10102111148110	40	6	25	M6	100	1
BT 40WE06 160 AD/6.3G 15000 SL	K10102111175110	40	6	25	M6	160	1
BT 40WE 08 050 AD/6.3G 15000 SL	K10102112111110	40	8	28	M8	50	1
BT 40WE 08 100 AD/6.3G 15000 SL	K10102112148110	40	8	28	M8	100	1
BT 40WE 08 160 AD/6.3G 15000 SL	K10102112175110	40	8	28	M8	160	1
BT 40WE 10 063 AD/6.3G 15000 SL	K10102113119110	40	10	35	M10	63	1
BT 40WE 10 100 AD/6.3G 15000 SL	K10102113148110	40	10	35	M10	100	1
BT 40WE 10 160 AD/6.3G 15000 SL	K10102113175110	40	10	35	M10	160	1
BT 40WE 12 063 AD/6.3G 15000 SL	K10102114119110	40	12	42	M12	63	1
BT 40WE 12 100 AD/6.3G 15000 SL	K10102114148110	40	12	42	M12	100	1
BT 40WE 12 160 AD/6.3G 15000 SL	K10102114175110	40	12	42	M12	160	1
BT 40WE 14 063 AD/6.3G 15000 SL	K10102258119110	40	14	44	M12	63	1
BT 40WE 14 100 AD/6.3G 15000 SL	K10102258148110	40	14	44	M12	100	1
BT 40WE 14 160 AD/6.3G 15000 SL	K10102258175110	40	14	44	M12	160	1
BT 40WE 16 063 AD/6.3G 15000 SL	K10102115119110	40	16	48	M14	63	1
BT 40WE 16 100 AD/6.3G 15000 SL	K10102115148110	40	16	48	M14	100	1
BT 40WE 16 160 AD/6.3G 15000 SL	K10102115175110	40	16	48	M14	160	1
BT 40WE 18 063 AD/6.3G 15000 SL	K10102259119110	40	18	50	M14	63	1
BT 40WE 18 100 AD/6.3G 15000 SL	K10102259148110	40	18	50	M14	100	1
BT 40WE 18 160 AD/6.3G 15000 SL	K10102259175110	40	18	50	M14	160	1
BT 40WE 20 063 AD/6.3G 15000 SL	K10102116119110	40	20	52	M16	63	1
BT 40WE 20 100 AD/6.3G 15000 SL	K10102116148110	40	20	52	M16	100	1
BT 40WE 20 160 AD/6.3G 15000 SL	K10102116175110	40	20	52	M16	160	1

Note: • All Dimensions are in mm
• These Holders are most suitable for Weldon Type End Mill as per standard DIN 1835 - B

Continued...

Maximum Run out of the Internal Dia with respect to the External Taper 0.005 mm

BT (MAS 403)
DIN ISO 7388 - 2
Holders

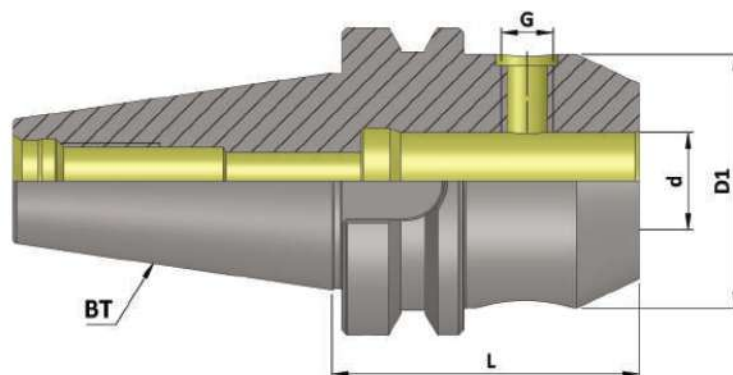

BT (MAS 403) (WE) (AD) (JD)

(Balanced to 6.3 G 15000 RPM)

Item Name	Item Code	ISO	d	D1	G	L	Screw Qty.
BT 40 WE 25 090 AD/6.3G15000 SL	K10102117140110	40	25	65	M18X2	90	2
BT 40 WE 25 160 AD/6.3G15000 SL	K10102117175110	40	25	65	M18X2	160	2
BT 40 WE 32 100 AD/6.3G15000 SL	K10102118148110	40	32	72	M20X2	100	2
BT 40 WE 32 160 AD/6.3G15000 SL	K10102118175110	40	32	72	M20X2	160	2
BT 40 WE 40 105 AD/6.3G15000 SL	K10102119152110	40	40	80	M20X2	105	2
BT 40 WE 40 160 AD/6.3G15000 SL	K10102119175110	40	40	80	M20X2	160	2

BT 50 WE 06 063 AD/6.3G15000 SL	K10103111119110	50	6	25	M6	63	1
BT 50 WE 06 100 AD/6.3G15000 SL	K10103111148110	50	6	25	M6	100	1
BT 50 WE 06 160 AD/6.3G15000 SL	K10103111175110	50	6	25	M6	160	1
BT 50 WE 08 063 AD/6.3G15000 SL	K10103112119110	50	8	28	M8	63	1
BT 50 WE 08 100 AD/6.3G15000 SL	K10103112148110	50	8	28	M8	100	1
BT 50 WE 08 160 AD/6.3G15000 SL	K10103112175110	50	8	28	M8	160	1
BT 50 WE 10 080 AD/6.3G15000 SL	K10103113125110	50	10	35	M10	80	1
BT 50 WE 10 100 AD/6.3G15000 SL	K10103113148110	50	10	35	M10	100	1
BT 50 WE 10 160 AD/6.3G15000 SL	K10103113175110	50	10	35	M10	160	1
BT 50 WE 12 080 AD/6.3G15000 SL	K10103114131110	50	12	42	M12	80	1
BT 50 WE 12 100 AD/6.3G15000 SL	K10103114148110	50	12	42	M12	100	1
BT 50 WE 12 160 AD/6.3G15000 SL	K10103114175110	50	12	42	M12	160	1
BT 50 WE 14 080 AD/6.3G15000 SL	K10103258131110	50	14	44	M12	80	1
BT 50 WE 14 100 AD/6.3G15000 SL	K10103258148110	50	14	44	M12	100	1
BT 50 WE 14 160 AD/6.3G15000 SL	K10103258175110	50	14	44	M12	160	1
BT 50 WE 16 080 AD/6.3G15000 SL	K10103115131110	50	16	48	M14	80	1
BT 50 WE 16 100 AD/6.3G15000 SL	K10103115148110	50	16	48	M14	100	1
BT 50 WE 16 160 AD/6.3G15000 SL	K10103115175110	50	16	48	M14	160	1
BT 50 WE 18 080 AD/6.3G15000 SL	K10103259131110	50	18	50	M14	80	1
BT 50 WE 18 100 AD/6.3G15000 SL	K10103259148110	50	18	50	M14	100	1
BT 50 WE 18 160 AD/6.3G15000 SL	K10103259175110	50	18	50	M14	160	1
BT 50 WE 20 080 AD/6.3G15000 SL	K10103116131110	50	20	52	M16	80	1
BT 50 WE 20 100 AD/6.3G15000 SL	K10103116148110	50	20	52	M16	100	1
BT 50 WE 20 160 AD/6.3G15000 SL	K10103116175110	50	20	52	M16	160	1

Note: • All Dimensions are in mm
• These Holders are most suitable for Weldon Type End Mill as per standard DIN 1835 - B

Maximum Run out of the Internal Dia with respect to the External Taper 0.005 mm

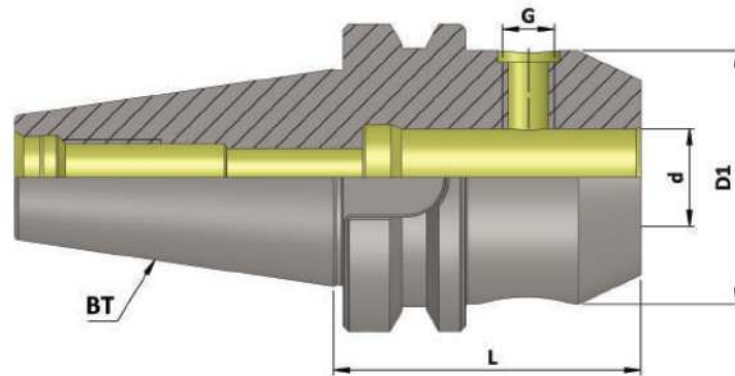

BT (MAS 403)
DIN ISO 7388 - 2
Holders

BT (MAS 403) (WE) (AD) (JD)

(Balanced to 6.3 G 15000 RPM)

Item Name	Item Code	ISO	d	D1	G	L	Screw Qty.
BT 50 WE 25 100 AD/6.3G 15000 SL	K10103117148110	50	25	65	M18X2	100	2
BT 50 WE 25 160 AD/6.3G 15000 SL	K10103117175110	50	25	65	M18X2	160	2
BT 50 WE 32 105 AD/6.3G 15000 SL	K10103118152110	50	32	72	M20X2	105	2
BT 50 WE 32 160 AD/6.3G 15000 SL	K10103118175110	50	32	72	M20X2	160	2
BT 50 WE 40 115 AD/6.3G 15000 SL	K10103119159110	50	40	80	M20X2	115	2
BT 50 WE 40 160 AD/6.3G 15000 SL	K10103119175110	50	40	80	M20X2	160	2
BT 50 WE 50 125 AD/6.3G 15000 SL	K10103120164110	50	50	100	M24X2	125	2

Note: • All Dimensions are in mm
• These Holders are most suitable for Weldon Type End Mill as per standard DIN 1835 - B

Maximum Run out of the Internal Dia with respect to the External Taper 0.005 mm

BT (MAS 403)
DIN ISO 7388 - 2
Holders

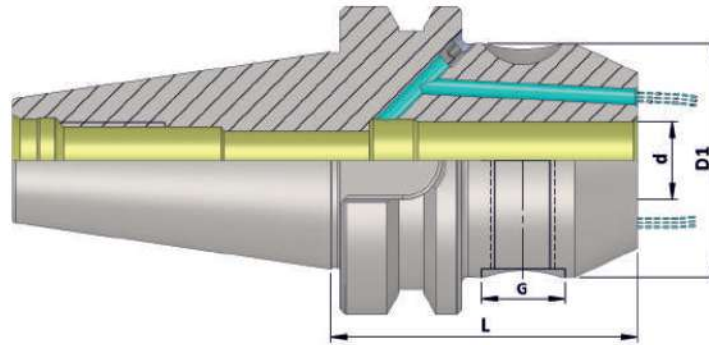

BT (MAS 403) (WE) (FCC) (AD) (JD)

(Balanced to 2.5 G 25000 RPM)

Item Name	Item Code	ISO	d	D1	G	L	Screw Qty.
BT30 WE06 050 FCC AD/2.5G 25000 SL	K10101111111262	30	6	25	M6	50	1
BT30 WE08 050 FCC AD/2.5G 25000 SL	K10101112111262	30	8	28	M8	50	1
BT30 WE10 050 FCC AD/2.5G 25000 SL	K10101113111262	30	10	35	M10	50	1
BT30 WE12 055 FCC AD/2.5G 25000 SL	K10101114115262	30	12	42	M12	55	1
BT30 WE14 055 FCC AD/2.5G 25000 SL	K10101258115262	30	14	44	M12	55	1
BT30 WE16 063 FCC AD/2.5G 25000 SL	K10101115563262	30	16	48	M14	63	1
BT30 WE18 063 FCC AD/2.5G 25000 SL	K10101259563262	30	18	50	M14	63	1
BT30 WE20 070 FCC AD/2.5G 25000 SL	K10101116125262	30	20	52	M16	70	1

Note: • All Dimensions are in mm
• These Holders are most suitable for Weldon Type End Mill as per standard DIN 1835 - B

Maximum Run out of the Internal Dia with respect to the External Taper 0.005 mm

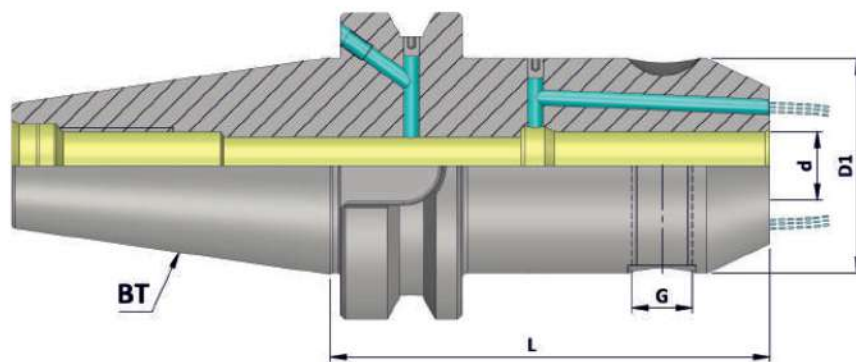

BT (MAS 403)
DIN ISO 7388 - 2
Holders

BT (MAS 403) (WE) (FCC) (AD+B) (JD/JF)

(Balanced to 2.5 G 25000 RPM)

Item Name	Item Code	ISO	d	D1	G	L	Screw Qty.
BT40 WE06 050 FCC AD+B/2.5G 25000 SL	K10102111111263	40	6	25	M6	50	1
BT40 WE06 100 FCC AD+B/2.5G 25000 SL	K10102111148263	40	6	25	M6	100	1
BT40 WE06 160 FCC AD+B/2.5G 25000 SL	K10102111175263	40	6	25	M6	160	1
BT40 WE08 050 FCC AD+B/2.5G 25000 SL	K10102112111263	40	8	28	M8	50	1
BT40 WE08 100 FCC AD+B/2.5G 25000 SL	K10102112148263	40	8	28	M8	100	1
BT40 WE08 160 FCC AD+B/2.5G 25000 SL	K10102112175263	40	8	28	M8	160	1
BT40 WE10 063 FCC AD+B/2.5G 25000 SL	K10102113563263	40	10	35	M10	63	1
BT40 WE10 100 FCC AD+B/2.5G 25000 SL	K10102113148263	40	10	35	M10	100.	1
BT40 WE10 160 FCC AD+B/2.5G 25000 SL	K10102113175263	40	10	35	M10	160	1
BT40 WE12 063 FCC AD+B/2.5G 25000 SL	K10102114563263	40	12	42	M12	63	1
BT40 WE12 100 FCC AD+B/2.5G 25000 SL	K10102114148263	40	12	42	M12	100	1
BT40 WE12 160 FCC AD+B/2.5G 25000 SL	K10102114175263	40	12	42	M12	160	1
BT40 WE14 063 FCC AD+B/2.5G 25000 SL	K10102258563263	40	14	44	M12	63	1
BT40 WE14 100 FCC AD+B/2.5G 25000 SL	K10102258148263	40	14	44	M12	100	1
BT40 WE14 160 FCC AD+B/2.5G 25000 SL	K10102258175263	40	14	44	M12	160	1
BT40 WE16 063 FCC AD+B/2.5G 25000 SL	K10102115563263	40	16	48	M14	63	1
BT40 WE16 100 FCC AD+B/2.5G 25000 SL	K10102115148263	40	16	48	M14	100	1
BT40 WE16 160 FCC AD+B/2.5G 25000 SL	K10102115175263	40	16	48	M14	160	1
BT40 WE18 063 FCC AD+B/2.5G 25000 SL	K10102259563263	40	18	50	M14	63	1
BT40 WE18 100 FCC AD+B/2.5G 25000 SL	K10102259148263	40	18	50	M14	100	1
BT40 WE18 160 FCC AD+B/2.5G 25000 SL	K10102259175263	40	18	50	M14	160	1
BT40 WE20 063 FCC AD+B/2.5G 25000 SL	K10102116563263	40	20	52	M16	63	1
BT40 WE20 100 FCC AD+B/2.5G 25000 SL	K10102116148263	40	20	52	M16	100	1
BT40 WE20 160 FCC AD+B/2.5G 25000 SL	K10102116175263	40	20	52	M16	160	1
BT40 WE25 090 FCC AD+B/2.5G 25000 SL	K10102117140263	40	25	65	M18X2	90	2
BT40 WE25 160 FCC AD+B/2.5G 25000 SL	K10102117175263	40	25	65	M18X2	160	2
BT40 WE32 100 FCC AD+B/2.5G 25000 SL	K10102118148263	40	32	72	M20X2	100	2
BT40 WE32 160 FCC AD+B/2.5G 25000 SL	K10102118175263	40	32	72	M20X2	160	2
BT40 WE40 105 FCC AD+B/2.5G 25000 SL	K10102119152263	40	40	80	M20X2	105	2
BT40 WE40 160 FCC AD+B/2.5G 25000 SL	K10102119175263	40	40	80	M20X2	160	2

Note: • All Dimensions are in mm
• These Holders are most suitable for Weldon Type End Mill as per standard DIN 1835 - B

Maximum Run out of the Internal Dia with respect to the External Taper 0.005 mm

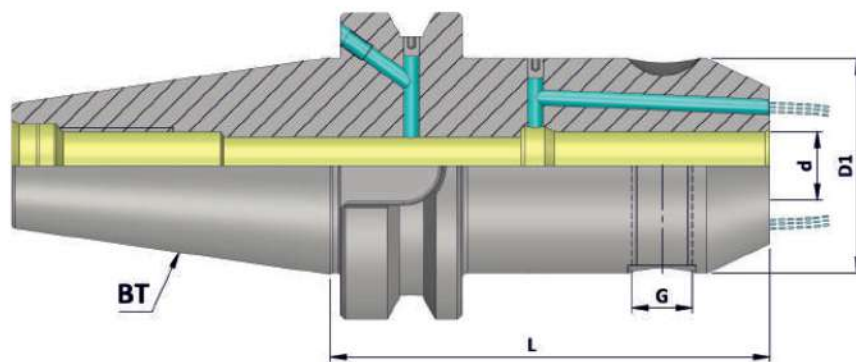

BT (MAS 403)
DIN ISO 7388 - 2
Holders

BT (MAS 403) (WE) (FCC) (AD+B) (JD/JF)

(Balanced to 2.5 G 25000 RPM)

Item Name	Item Code	ISO	d	D1	G	L	Screw Qty.
BT50 WE06 063 FCC AD+B/2.5G 25000 SL	K10103111563263	50	6	25	M6	63	1
BT50 WE06 100 FCC AD+B/2.5G 25000 SL	K10103111148263	50	6	25	M6	100	1
BT50 WE06 160 FCC AD+B/2.5G 25000 SL	K10103111175263	50	6	25	M6	160	1
BT50 WE08 063 FCC AD+B/2.5G 25000 SL	K10103112563263	50	8	28	M8	63	1
BT50 WE08 100 FCC AD+B/2.5G 25000 SL	K10103112148263	50	8	28	M8	100	1
BT50 WE08 160 FCC AD+B/2.5G 25000 SL	K10103112175263	50	8	28	M8	160	1
BT50 WE10 080 FCC AD+B/2.5G 25000 SL	K10103113131263	50	10	35	M10	80	1
BT50 WE10 100 FCC AD+B/2.5G 25000 SL	K10103113148263	50	10	35	M10	100	1
BT50 WE10 160 FCC AD+B/2.5G 25000 SL	K10103113175263	50	10	35	M10	160	1
BT50 WE12 080 FCC AD+B/2.5G 25000 SL	K10103114131263	50	12	42	M12	80	1
BT50 WE12 100 FCC AD+B/2.5G 25000 SL	K10103114148263	50	12	42	M12	100	1
BT50 WE12 160 FCC AD+B/2.5G 25000 SL	K10103114175263	50	12	42	M12	160	1
BT50 WE14 080 FCC AD+B/2.5G 25000 SL	K10103258131263	50	14	44	M12	80	1
BT50 WE14 100 FCC AD+B/2.5G 25000 SL	K10103258148263	50	14	44	M12	100	1
BT50 WE14 160 FCC AD+B/2.5G 25000 SL	K10103258175263	50	14	44	M12	160	1
BT50 WE16 080 FCC AD+B/2.5G 25000 SL	K10103115131263	50	16	48	M14	80	1
BT50 WE16 100 FCC AD+B/2.5G 25000 SL	K10103115148263	50	16	48	M14	100	1
BT50 WE16 160 FCC AD+B/2.5G 25000 SL	K10103115175263	50	16	48	M14	160	1
BT50 WE18 080 FCC AD+B/2.5G 25000 SL	K10103259131263	50	18	50	M14	80	1
BT50 WE18 100 FCC AD+B/2.5G 25000 SL	K10103259148263	50	18	50	M14	100	1
BT50 WE18 160 FCC AD+B/2.5G 25000 SL	K10103259175263	50	18	50	M14	160	1
BT50 WE20 080 FCC AD+B/2.5G 25000 SL	K10103116131263	50	20	52	M16	80	1
BT50 WE20 100 FCC AD+B/2.5G 25000 SL	K10103116148263	50	20	52	M16	100	1
BT50 WE20 160 FCC AD+B/2.5G 25000 SL	K10103116175263	50	20	52	M16	160	1
BT50 WE25 100 FCC AD+B/2.5G 25000 SL	K10103117148263	50	25	65	M18X2	100	2
BT50 WE25 160 FCC AD+B/2.5G 25000 SL	K10103117175263	50	25	65	M18X2	160	2
BT50 WE32 105 FCC AD+B/2.5G 25000 SL	K10103118152263	50	32	72	M20X2	105	2
BT50 WE32 160 FCC AD+B/2.5G 25000 SL	K10103118175263	50	32	72	M20X2	160	2
BT50 WE40 115 FCC AD+B/2.5G 25000 SL	K10103119159263	50	40	80	M20X2	115	2
BT50 WE40 160 FCC AD+B/2.5G 25000 SL	K10103119175263	50	40	80	M20X2	160	2
BT50 WE50 125 FCC AD+B/2.5G 25000 SL	K10103120164263	50	50	100	M24X2	125	2

Note: • All Dimensions are in mm
• These Holders are most suitable for Weldon Type End Mill as per standard DIN 1835 - B

Maximum Run out of the External Dia with respect to the External Taper 0.005 mm

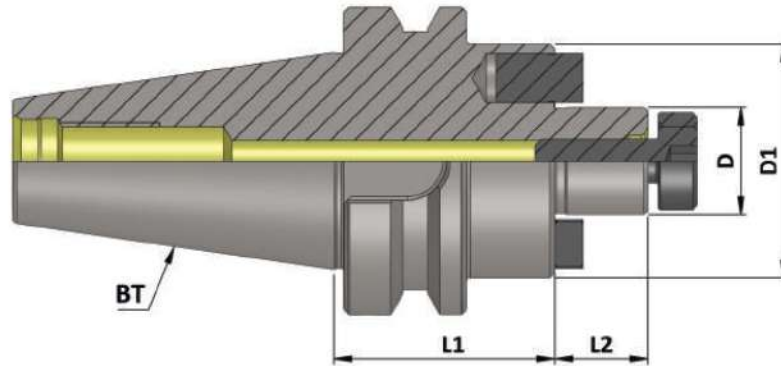

BT (MAS 403)
DIN ISO 7388 - 2
Holders

BT (MAS 403) FMH (AD) (JD)

(Balanced to 6.3 G 15000 RPM)

Item Name	Item Code	ISO	D	D1	L1	L2
BT 30 FMH16 035 AD/6.3G 15000 SL S.P.S	K10101126104232	30	16	38	35	17
BT 30 FMH22 040 AD/6.3G 15000 SL S.P.S	K10101127106232	30	22	48	40	19
BT 30 FMH27 040 AD/6.3G 15000 SL S.P.S	K10101128106232	30	27	58	40	21
BT 40 FMH16 045 AD/6.3G 15000 SL S.P.S	K10102126108232	40	16	38	45	17
BT 40 FMH16 100 AD/6.3G 15000 SL S.P.S	K10102126148232	40	16	38	100	17
BT 40 FMH16 160 AD/6.3G 15000 SL S.P.S	K10102126175232	40	16	38	160	17
BT 40 FMH22 045 AD/6.3G 15000 SL S.P.S	K10102127108232	40	22	48	45	19
BT 40 FMH22 100 AD/6.3G 15000 SL S.P.S	K10102127148232	40	22	48	100	19
BT 40 FMH22 160 AD/6.3G 15000 SL S.P.S	K10102127175232	40	22	48	160	19
BT 40 FMH27 045 AD/6.3G 15000 SL S.P.S	K10102128108232	40	27	58	45	21
BT 40 FMH27 100 AD/6.3G 15000 SL S.P.S	K10102128148232	40	27	58	100	21
BT 40 FMH27 160 AD/6.3G 15000 SL S.P.S	K10102128175232	40	27	58	160	21
BT 40 FMH32 050 AD/6.3G 15000 SL S.P.S	K10102129111232	40	32	78	50	24
BT 40 FMH32 100 AD/6.3G 15000 SL S.P.S	K10102129148232	40	32	78	100	24
BT 40 FMH32 160 AD/6.3G 15000 SL S.P.S	K10102129175232	40	32	78	160	24
BT 40 FMH40 055 AD/6.3G 15000 SL S.P.S	K10102130115232	40	40	88	55	27
BT 40 FMH40 100 AD/6.3G 15000 SL S.P.S	K10102130148232	40	40	88	100	27
BT 40 FMH40 160 AD/6.3G 15000 SL S.P.S	K10102130175232	40	40	88	160	27
BT 50 FMH16 060 AD/6.3G 15000 SL S.P.S	K10103126117232	50	16	38	60	17
BT 50 FMH16 100 AD/6.3G 15000 SL S.P.S	K10103126148232	50	16	38	100	17
BT 50 FMH16 160 AD/6.3G 15000 SL S.P.S	K10103126175232	50	16	38	160	17
BT 50 FMH22 060 AD/6.3G 15000 SL S.P.S	K10103127117232	50	22	48	60	19
BT 50 FMH22 100 AD/6.3G 15000 SL S.P.S	K10103127148232	50	22	48	100	19
BT 50 FMH22 160 AD/6.3G 15000 SL S.P.S	K10103127175232	50	22	48	160	19
BT 50 FMH27 060 AD/6.3G 15000 SL S.P.S	K10103128117232	50	27	58	60	21
BT 50 FMH27 100 AD/6.3G 15000 SL S.P.S	K10103128148232	50	27	58	100	21
BT 50 FMH27 160 AD/6.3G 15000 SL S.P.S	K10103128175232	50	27	58	160	21
BT 50 FMH32 060 AD/6.3G 15000 SL S.P.S	K10103129117232	50	32	78	60	24
BT 50 FMH32 100 AD/6.3G 15000 SL S.P.S	K10103129148232	50	32	78	100	24
BT 50 FMH32 160 AD/6.3G 15000 SL S.P.S	K10103129175232	50	32	78	160	24
BT 50 FMH40 060 AD/6.3G 15000 SL S.P.S	K10103130117232	50	40	88	60	27
BT 50 FMH40 100 AD/6.3G 15000 SL S.P.S	K10103130148232	50	40	88	100	27
BT 50 FMH40 160 AD/6.3G 15000 SL S.P.S	K10103130175232	50	40	88	160	27

Note: All Dimensions are in mm

Maximum Run out of the External Dia with respect to the External Taper 0.005 mm

BT (MAS 403)
DIN ISO 7388 - 2
Holders

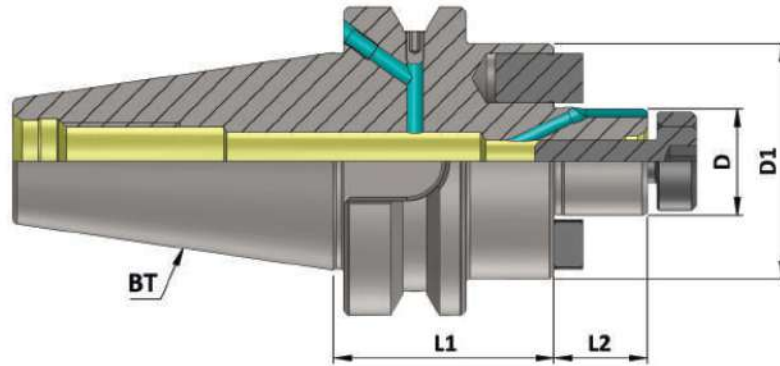

BT (MAS403) (FMH-K) (AD+ B) (JD/JF)

(Balanced to 6.3 G 15000 RPM)

Item Name	Item Code	ISO	D	D1	L1	L2
BT 40 FMH-K16 045 AD+B/6.3G 15000 SL SP.S	K10102131108234	40	16	38	45	17
BT 40 FMH-K16 100 AD+B/6.3G 15000 SL SP.S	K10102131148234	40	16	38	100	17
BT 40 FMH-K16 160 AD+B/6.3G 15000 SL SP.S	K10102131175234	40	16	38	160	17
BT 40 FMH-K22 045 AD+B/6.3G 15000 SL SP.S	K10102132108234	40	22	48	45	19
BT 40 FMH-K22 100 AD+B/6.3G 15000 SL SP.S	K10102132148234	40	22	48	100	19
BT 40 FMH-K22 160 AD+B/6.3G 15000 SL SP.S	K10102132175234	40	22	48	160	19
BT 40 FMH-K27 045 AD+B/6.3G 15000 SL SP.S	K10102133108234	40	27	58	45	21
BT 40 FMH-K27 100 AD+B/6.3G 15000 SL SP.S	K10102133148234	40	27	58	100	21
BT 40 FMH-K27 160 AD+B/6.3G 15000 SL SP.S	K10102133175234	40	27	58	160	21
BT 40 FMH-K32 050 AD+B/6.3G 15000 SL SP.S	K10102134111234	40	32	78	50	24
BT 40 FMH-K32 100 AD+B/6.3G 15000 SL SP.S	K10102134148234	40	32	78	100	24
BT 40 FMH-K32 160 AD+B/6.3G 15000 SL SP.S	K10102134175234	40	32	78	160	24
BT 40 FMH-K40 055 AD+B/6.3G 15000 SL SP.S	K10102135115234	40	40	88	55	27
BT 40 FMH-K40 100 AD+B/6.3G 15000 SL SP.S	K10102135148234	40	40	88	100	27
BT 40 FMH-K40 160 AD+B/6.3G 15000 SL SP.S	K10102135175234	40	40	88	160	27

BT 50 FMH-K16 060 AD+B/6.3G 15000 SL SP.S	K10103131117234	50	16	38	60	17
BT 50 FMH-K16 100 AD+B/6.3G 15000 SL SP.S	K10103131148234	50	16	38	100	17
BT 50 FMH-K16 160 AD+B/6.3G 15000 SL SP.S	K10103131175234	50	16	38	160	17
BT 50 FMH-K22 060 AD+B/6.3G 15000 SL SP.S	K10103132117234	50	22	48	60	19
BT 50 FMH-K22 100 AD+B/6.3G 15000 SL SP.S	K10103132148234	50	22	48	100	19
BT 50 FMH-K22 160 AD+B/6.3G 15000 SL SP.S	K10103132175234	50	22	48	160	19
BT 50 FMH-K27 060 AD+B/6.3G 15000 SL SP.S	K10103133117234	50	27	58	60	21
BT 50 FMH-K27 100 AD+B/6.3G 15000 SL SP.S	K10103133148234	50	27	58	100	21
BT 50 FMH-K27 160 AD+B/6.3G 15000 SL SP.S	K10103133175234	50	27	58	160	21
BT 50 FMH-K32 060 AD+B/6.3G 15000 SL SP.S	K10103134117234	50	32	78	60	24
BT 50 FMH-K32 100 AD+B/6.3G 15000 SL SP.S	K10103134148234	50	32	78	100	24
BT 50 FMH-K32 160 AD+B/6.3G 15000 SL SP.S	K10103134175234	50	32	78	160	24
BT 50 FMH-K40 060 AD+B/6.3G 15000 SL SP.S	K10103135117234	50	40	88	60	27
BT 50 FMH-K40 100 AD+B/6.3G 15000 SL SP.S	K10103135148234	50	40	88	100	27
BT 50 FMH-K40 160 AD+B/6.3G 15000 SL SP.S	K10103135175234	50	40	88	160	27

Note: All Dimensions are in mm

Maximum Run out of the External Dia with respect to the External Taper 0.005 mm

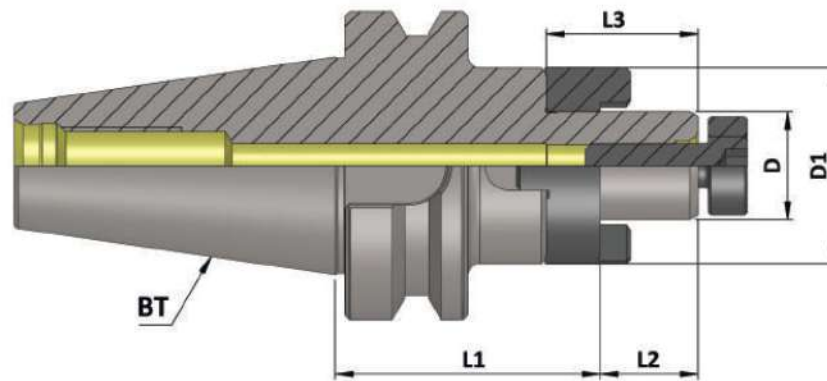

BT (MAS 403) (CSMA)

(Balanced to 6.3 G 15000 RPM)

Item Name	Item Code	ISO	D	D1	L1	L2	L3
BT 30 CSMA16 050 AD/6.3G 15000 SL S.P.S	K10101121111232	30	16	32	50	17	27
BT 30 CSMA22 050 AD/6.3G 15000 SL S.P.S	K10101122111232	30	22	40	50	19	31
BT 30 CSMA27 055 AD/6.3G 15000 SL S.P.S	K10101123115232	30	27	48	55	21	33

BT 40 CSMA16 055 AD/6.3G 15000 SL S.P.S	K10102121115232	40	16	32	55	17	27
BT 40 CSMA16 100 AD/6.3G 15000 SL S.P.S	K10102121148232	40	16	32	100	17	27
BT 40 CSMA16 160 AD/6.3G 15000 SL S.P.S	K10102121175232	40	16	32	160	17	27
BT 40 CSMA22 055 AD/6.3G 15000 SL S.P.S	K10102122115232	40	22	40	55	19	31
BT 40 CSMA22 100 AD/6.3G 15000 SL S.P.S	K10102122148232	40	22	40	100	19	31
BT 40 CSMA22 160 AD/6.3G 15000 SL S.P.S	K10102122175232	40	22	40	160	19	31
BT 40 CSMA27 055 AD/6.3G 15000 SL S.P.S	K10102123115232	40	27	48	55	21	33
BT 40 CSMA27 100 AD/6.3G 15000 SL S.P.S	K10102123148232	40	27	48	100	21	33
BT 40 CSMA27 160 AD/6.3G 15000 SL S.P.S	K10102123175232	40	27	48	160	21	33
BT 40 CSMA32 060 AD/6.3G 15000 SL S.P.S	K10102124117232	40	32	58	60	24	38
BT 40 CSMA32 100 AD/6.3G 15000 SL S.P.S	K10102124148232	40	32	58	100	24	38
BT 40 CSMA32 160 AD/6.3G 15000 SL S.P.S	K10102124175232	40	32	58	160	24	38
BT 40 CSMA40 060 AD/6.3G 15000 SL S.P.S	K10102125117232	40	40	70	60	27	41
BT 40 CSMA40 100 AD/6.3G 15000 SL S.P.S	K10102125148232	40	40	70	100	27	41
BT 40 CSMA40 160 AD/6.3G 15000 SL S.P.S	K10102125175232	40	40	70	160	27	41

BT 50 CSMA16 070 AD/6.3G 15000 SL S.P.S	K10103121125232	50	16	32	70	17	27
BT 50 CSMA16 100 AD/6.3G 15000 SL S.P.S	K10103121148232	50	16	32	100	17	27
BT 50 CSMA16 160 AD/6.3G 15000 SL S.P.S	K10103121175232	50	16	32	160	17	27
BT 50 CSMA22 070 AD/6.3G 15000 SL S.P.S	K10103122125232	50	22	40	70	19	31
BT 50 CSMA22 100 AD/6.3G 15000 SL S.P.S	K10103122148232	50	22	40	100	19	31
BT 50 CSMA22 160 AD/6.3G 15000 SL S.P.S	K10103122175232	50	22	40	160	19	31
BT 50 CSMA27 070 AD/6.3G 15000 SL S.P.S	K10103123125232	50	27	48	70	21	33
BT 50 CSMA27 100 AD/6.3G 15000 SL S.P.S	K10103123148232	50	27	48	100	21	33
BT 50 CSMA27 160 AD/6.3G 15000 SL S.P.S	K10103123175232	50	27	48	160	21	33
BT 50 CSMA32 070 AD/6.3G 15000 SL S.P.S	K10103124125232	50	32	58	70	24	38
BT 50 CSMA32 100 AD/6.3G 15000 SL S.P.S	K10103124148232	50	32	58	100	24	38
BT 50 CSMA32 160 AD/6.3G 15000 SL S.P.S	K10103124175232	50	32	58	160	24	38
BT 50 CSMA40 070 AD/6.3G 15000 SL S.P.S	K10103125125232	50	40	70	70	27	41
BT 50 CSMA40 100 AD/6.3G 15000 SL S.P.S	K10103125148232	50	40	70	100	27	41
BT 50 CSMA40 160 AD/6.3G 15000 SL S.P.S	K10103125175232	50	40	70	160	27	41

Note: All Dimensions are in mm

Maximum Run out of the Internal Taper with respect to the External Taper 0.005 mm

BT (MAS 403)
 DIN ISO 7388 - 2
 Holders

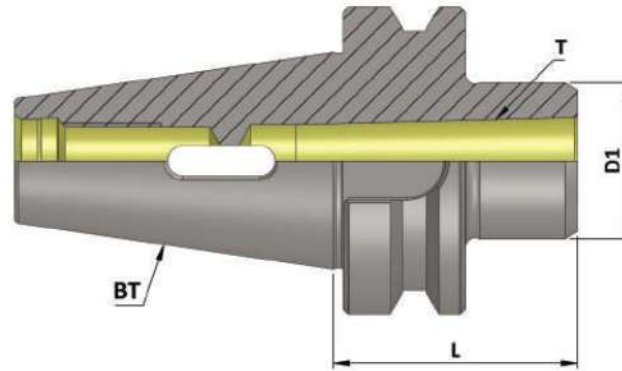

BT (MAS 403) (MTA)

(Balanced to 6.3 G 15000 RPM)

Item Name	Item Code	ISO	Morse Taper (T)	D1	L
BT 30 MT01 050 6.3G 15000 SL	K10101447111122	30	1	25	50
BT 30 MT02 060 6.3G 15000 SL	K10101448117122	30	2	32	60
BT 30 MT03 075 6.3G 15000 SL	K10101449127122	30	3	40	75
BT 40 MT01 050 6.3G 15000 SL	K10102447111122	40	1	25	50
BT 40 MT01 115 6.3G 15000 SL	K10102447159122	40	1	25	115
BT 40 MT02 050 6.3G 15000 SL	K10102448111122	40	2	32	50
BT 40 MT02 125 6.3G 15000 SL	K10102448164122	40	2	32	125
BT 40 MT03 070 6.3G 15000 SL	K10102449125122	40	3	40	70
BT 40 MT03 140 6.3G 15000 SL	K10102449169122	40	3	40	140
BT 40 MT04 095 6.3G 15000 SL	K10102451145122	40	4	48	95
BT 50 MT01 050 6.3G 15000 SL	K10103447111122	50	1	25	50
BT 50 MT01 120 6.3G 15000 SL	K10103447162122	50	1	25	120
BT 50 MT02 060 6.3G 15000 SL	K10103448117122	50	2	32	60
BT 50 MT02 140 6.3G 15000 SL	K10103448169122	50	2	32	140
BT 50 MT03 065 6.3G 15000 SL	K10103449123122	50	3	40	65
BT 50 MT03 150 6.3G 15000 SL	K10103449173122	50	3	40	150
BT 50 MT04 095 6.3G 15000 SL	K10103451145122	50	4	48	95
BT 50 MT04 180 6.3G 15000 SL	K10103451178122	50	4	48	180
BT 50 MT05 120 6.3G 15000 SL	K10103450162122	50	5	63	120
BT 50 MT05 220 6.3G 15000 SL	K10103450180122	50	5	63	220

Note: All Dimensions are in mm

Maximum Run out of the Internal Taper with respect to the External Taper 0.005 mm

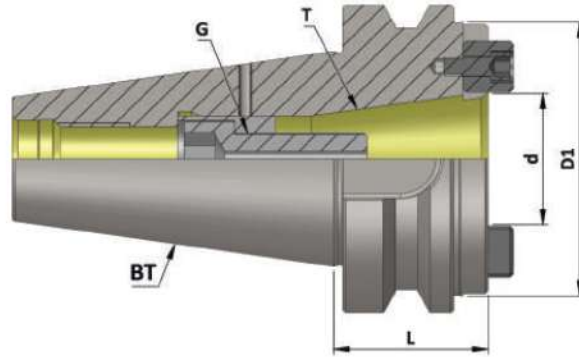

BT (MAS 403)
DIN ISO 7388 - 2
Holders

BT (MAS 403) Reduction Sleeve

Item Name	Item Code	ISO	d	D1	T	L	G
BT 50 x BT 40 REDUCTION SLEEVE	K10103345486127	50	44.45	88.80	7:24	49	M 16

Note: All Dimensions are in mm

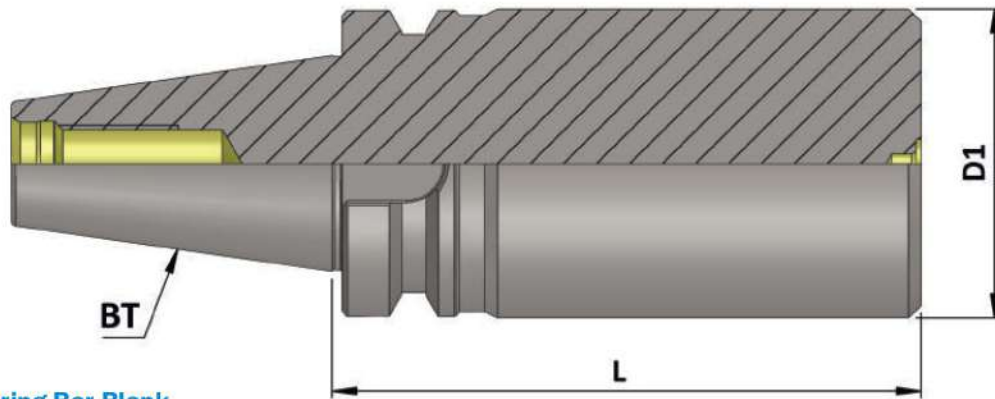

BT (MAS 403) Boring Bar Blank

Item Name	Item Code	ISO	D1	L
BT 40 BORING BAR BLANK DIA 63.5 L 120	K10102173498127	40	63.5	120
BT 40 BORING BAR BLANK DIA 63.5 L 160	K10102173330127	40	63.5	160
BT 40 BORING BAR BLANK DIA 63.5 L 250	K10102173256224	40	63.5	250
BT 50 BORING BAR BLANK DIA 80.0 L 160	K10103264330127	50	80	160
BT 50 BORING BAR BLANK DIA 80.0 L 200	K10103264237127	50	80	200
BT 50 BORING BAR BLANK DIA 80.0 L 300	K10103264257127	50	80	300
BT 50 BORING BAR BLANK DIA 97.0 L 315	K10103265329127	50	97	315

Note: All Dimensions are in mm

Maximum Run out of the External Dia with respect to the External Taper 0.003 mm

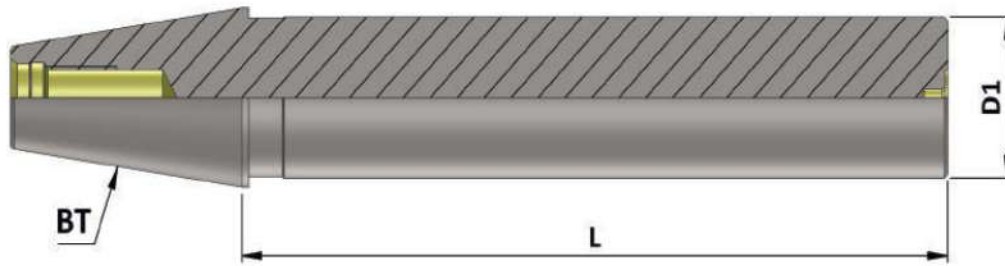

BT (MAS 403)
DIN ISO 7388 - 2
Holders

BT (MAS 403) Master Mandrell

(Sub Zero Treated)

Item Name	Item Code	ISO	D1	L
BT 30 MASTER MANDRELL DIA 32 L 250	K10192164256127	30	32	250
BT 40 MASTER MANDRELL DIA 40 L 300	K10102166257127	40	40	300
BT 50 MASTER MANDRELL DIA 50 L 350	K10103166258127	50	50	350

Note: All Dimensions are in mm

Maximum Run out on the Mandrell with respect to the External Taper 0.050 mm

BT (MAS 403)
DIN ISO 7388 - 2
Holders

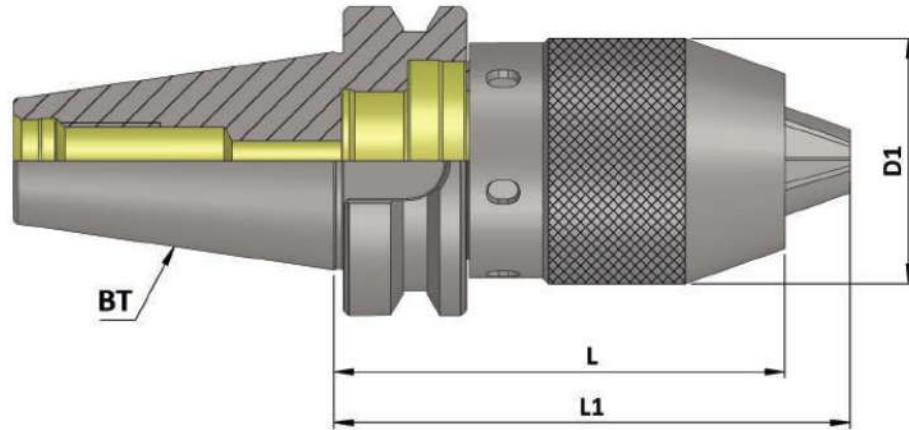

BT (MAS 403) (NCDC)

Item Name	Item Code	ISO	D1	L	L1
BT 30 NCDC 1-13 112.5	K10101167345122	30	50	112.5	125
BT 40 NCDC 1-13 092.5	K10102167143110	40	50	92.5	105
BT 50 NCDC 1-13 107.5	K10103167151110	50	50	107.5	120

Accessories:

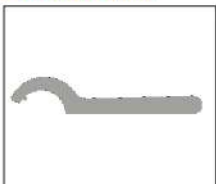

NCDC Spanner
Ref. Page No. 223

Note: All Dimensions are in mm



Die & Mould Chuck (DMC)

◆ Features:

- Small outside diameter.
- Best suitable for Die & Mould Industry.
- Most suitable for machining of cavities difficult to reach.
- High precision Runout < 0.005mm (4xd).
- All 'KTA' Die & Mould Chucks are subjected to Sub-zero treatment (-90° C). This treatment helps to prevent the holders from deformation for many years & hence increases the life.

◆ Capacity:

- DMC 06 (3mm to 6mm)
- DMC 08 (3mm to 8 mm)
- DMC 10 (3mm to 10mm)

◆ Available In Mountings:

- BT (MAS 403) (DIN ISO 7388 - 2)
- BBT (MAS 403)
- SK (DIN 69871) (DIN ISO 7388 - 1)
- HSK- A (DIN 69893-1)
- Cylindrical Shank

◆ Balancing:

- Balanced To 2.5 G 25000 RPM



Maximum Run out of the Internal Taper with respect to the External Taper < 0.005 mm

BT (MAS 403)
DIN ISO 7388 - 2
Holders

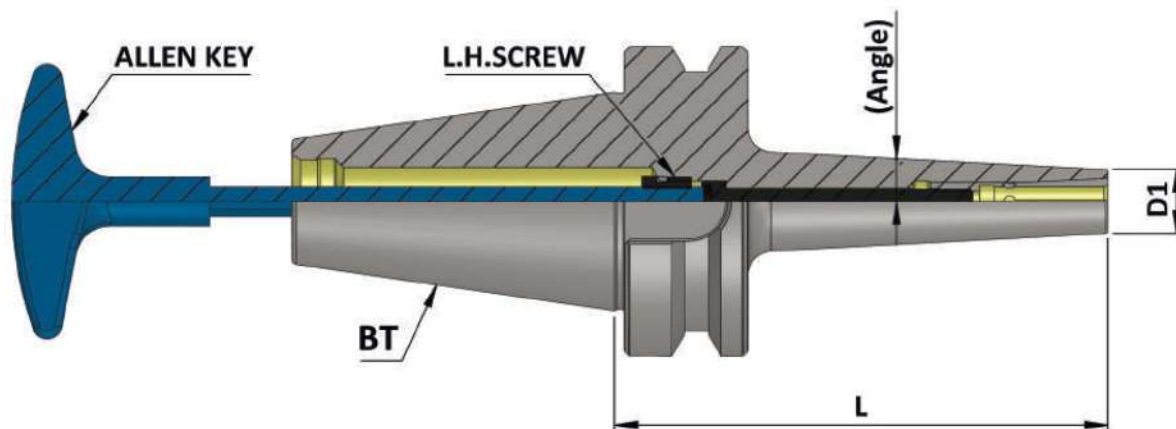

BT (MAS 403) (DMC)

(Balanced to 2.5 G 25000 RPM)

Item Name	Item Code	ISO	Gripping Range	D1	L	Angle	Suitable Collet	Screw	Allen Key
BT30 DMC 06 090 AD/2.5G 25000 SL	K10101161140114	30	3-6	13	90	3	DMC-6	M5	4X200
BT40 DMC 06 060 AD/2.5G 25000 SL	K10102161117129	40	3-6	13	60	3	DMC-6	M5	4X200
BT40 DMC 06 090 AD/2.5G 25000 SL	K10102161140129	40	3-6	13	90	3	DMC-6	M5	4X200
BT40 DMC 06 120 AD/2.5G 25000 SL	K10102161162129	40	3-6	13	120	3	DMC-6	M5	4X200
BT40 DMC 06 160 AD/2.5G 25000 SL	K10102161175227	40	3-6	13	160	3	DMC-6	M5	4X200
BT40 DMC 08 090 AD/2.5G 25000 SL	K10102162140129	40	3-8	22	90	3	DMC-8	M6	5X200
BT40 DMC 08 120 AD/2.5G 25000 SL	K10102162162129	40	3-8	22	120	3	DMC-8	M6	5X200
BT40 DMC 10 090 AD/2.5G 25000 SL	K10102163140129	40	3-10	28	90	-	DMC-10	M8	6X200
BT40 DMC 10 120 AD/2.5G 25000 SL	K10102163162129	40	3-10	28	120	-	DMC-10	M8	6X200
BT50 DMC 10 150 AD/2.5G 25000 SL	K10103163173129	50	3-10	28	150	-	DMC-10	M8	6X200

Accessories:



DMC Collet
Ref. Page No. 241

Note: All Dimensions are in mm



Power Milling Chuck (PMC)

◆ Features:

- 'KTA' Power Milling Chuck is Very Rigid & Precision.
- It is best for Drilling, Reaming & Milling Operations.
- The tool runs true less than 5 micron on 2D. Hence the tool life increases drastically.
- It's Unibody construction reduces the vibrations, This also helps to increase the tool life.
- All 'KTA' Power Milling Chucks are subjected to sub-zero treatment (-90° C). This treatment helps to prevent the holders from deformation for many years & hence increases the life.

◆ Available In Mountings:

- BT (MAS 403) (DIN ISO 7388 - 2)
- BBT (MAS 403)
- SK (DIN 69871) (DIN ISO 7388 - 1)
- HSK-A (DIN 69893-1)

◆ Balancing:

- Balanced To 6.3 G 15000 RPM



Maximum Run out of the Internal Dia with respect to the External Taper 0.005 mm

BT (MAS 403)
DIN ISO 7388 - 2
Holders

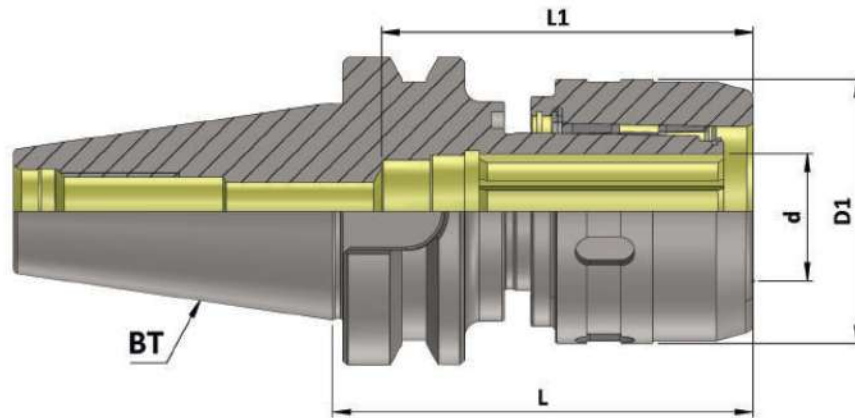

BT (MAS 403) (PMC)

(Balanced to 6.3 G 15000 RPM)

Item Name	Item Code	ISO	d	D1	L	L1
BT 30 C 20075 AD/6.3 G15000 SL	K1010145335212	30	20	54	75	70
BT 40 C 20080 AD/6.3 G15000SL	K10102453353129	40	20	54	80	70
BT 40 C 32090 AD/6.3 G15000SL	K10102453354129	40	32	72	90	100
BT 50 C 20105 AD/6.3 G15000 SL	K10103453355129	50	20	54	105	70
BT 50 C 32105 AD/6.3 G15000 SL	K10103453356129	50	32	72	105	100

Accessories:



Reduction Sleeve (RS)
Ref. Page No. 242

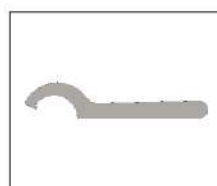

PMC Spanner
Ref. Page No. 223

Note: All Dimensions are in mm



Milling Cutter Arbor (MCA)

◆ Features:

- For Mounting of Screw type Modular Milling Cutters.
- Slim Design & hence easy to reach at deep cavities.
- Unibody Construction
- All 'KTA' Milling Cutter Arbors are subjected to Sub-zero treatment (-90° C). This treatment helps to prevent the holders from deformation for many years & hence increases the life.

◆ Available In Mountings :

- BT (MAS 403) (DIN ISO 7388 - 2)
- BBT (MAS 403)
- SK (DIN 69871) (DIN ISO 7388 - 1)
- HSK-A (DIN 69893-1)
- HSK-F (DIN 69893-6)

◆ Balancing :

- Balanced To 2.5 G 25000 RPM



Maximum Run out of the Internal Dia with respect to the External Taper 0.005 mm

BT (MAS 403)
DIN ISO 7388 - 2
Holders

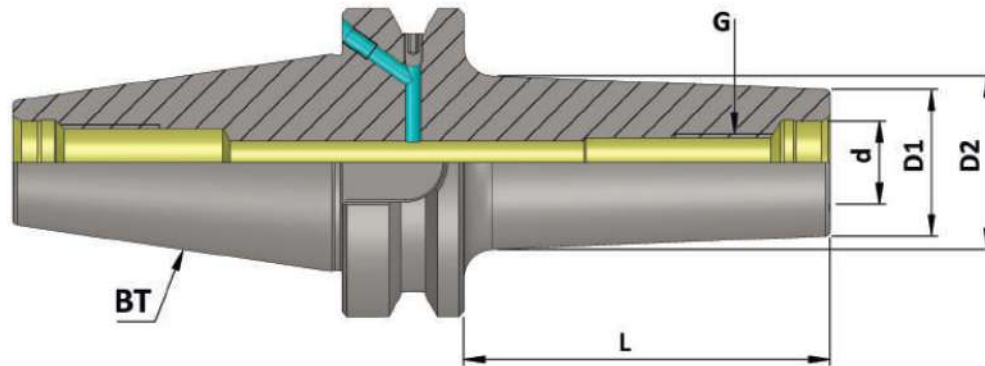

**SCREW-TYPE
MODULAR MILLING CUTTER**

BT (MAS 403) (MCA) (AD+B) (JD/JF)

(Balanced to 2.5 G 25000 RPM)

Item Name	Item Code	ISO	d	D1	D2	G	L
BT 40 MCA06 025 AD+B/2.5G 25000 SL	K10102137101230	40	6.5	10	13	M6	25
BT 40 MCA06 050 AD+B/2.5G 25000 SL	K10102137111230	40	6.5	10	20	M6	50
BT 40 MCA06 075 AD+B/2.5G 25000 SL	K10102137127230	40	6.5	10	23	M6	75
BT 40 MCA08 025 AD+B/2.5G 25000 SL	K10102138101230	40	8.5	13	15	M8	25
BT 40 MCA08 050 AD+B/2.5G 25000 SL	K10102138111230	40	8.5	13	23	M8	50
BT 40 MCA08 075 AD+B/2.5G 25000 SL	K10102138127230	40	8.5	13	23	M8	75
BT 40 MCA08 100 AD+B/2.5G 25000 SL	K10102138148230	40	8.5	13	25	M8	100
BT 40 MCA10 025 AD+B/2.5G 25000 SL	K10102139101230	40	10.5	18	20	M10	25
BT 40 MCA10 050 AD+B/2.5G 25000 SL	K10102139111230	40	10.5	18	23	M10	50
BT 40 MCA10 075 AD+B/2.5G 25000 SL	K10102139127230	40	10.5	18	28	M10	75
BT 40 MCA10 100 AD+B/2.5G 25000 SL	K10102139148230	40	10.5	18	32	M10	100
BT 40 MCA12 025 AD+B/2.5G 25000 SL	K10102140101230	40	12.5	21	24	M12	25
BT 40 MCA12 050 AD+B/2.5G 25000 SL	K10102140111230	40	12.5	21	24	M12	50
BT 40 MCA12 075 AD+B/2.5G 25000 SL	K10102140127230	40	12.5	21	31	M12	75
BT 40 MCA12 100 AD+B/2.5G 25000 SL	K10102140148230	40	12.5	21	33	M12	100
BT 40 MCA12 125 AD+B/2.5G 25000 SL	K10102140164230	40	12.5	21	36	M12	125
BT 40 MCA16 025 AD+B/2.5G 25000 SL	K10102141101230	40	17	29	29	M16	25
BT 40 MCA16 050 AD+B/2.5G 25000 SL	K10102141111230	40	17	29	34	M16	50
BT 40 MCA16 075 AD+B/2.5G 25000 SL	K10102141127230	40	17	29	34	M16	75
BT 40 MCA16 100 AD+B/2.5G 25000 SL	K10102141148230	40	17	29	36	M16	100
BT 40 MCA16 125 AD+B/2.5G 25000 SL	K10102141164230	40	17	29	40	M16	125
BT 40 MCA16 150 AD+B/2.5G 25000 SL	K10102141173230	40	17	29	42.5	M16	150

Note: All Dimensions are in mm

Maximum Run out of the Internal Dia with respect to the External Taper 0.005 mm

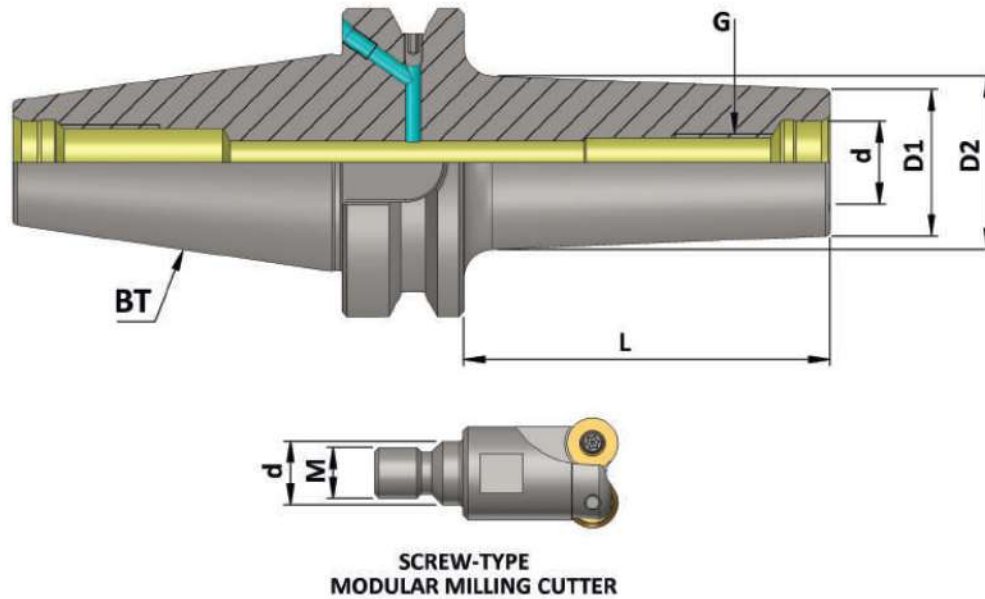

BT (MAS 403)
DIN ISO 7388 - 2
Holders

BT (MAS 403) (MCA) (AD+B) (JD/JF)

(Balanced to 2.5 G 25000 RPM)

Item Name	Item Code	ISO	d	D1	D2	G	L
BT 50 MCA08 050 AD+B/2.5G 25000 SL	K10103138111140	50	8.5	13	23	M8	50
BT 50 MCA08 100 AD+B/2.5G 25000 SL	K10103138148140	50	8.5	13	25	M8	100
BT 50 MCA08 150 AD+B/2.5G 25000 SL	K10103138173140	50	8.5	13	30	M8	150
BT 50 MCA10 050 AD+B/2.5G 25000 SL	K10103139111140	50	10.5	18	23	M10	50
BT 50 MCA10 100 AD+B/2.5G 25000 SL	K10103139148140	50	10.5	18	32	M10	100
BT 50 MCA10 150 AD+B/2.5G 25000 SL	K10103139173140	50	10.5	18	36.5	M10	150
BT 50 MCA12 050 AD+B/2.5G 25000 SL	K10103140111230	50	12.5	21	24	M12	50
BT 50 MCA12 100 AD+B/2.5G 25000 SL	K10103140148230	50	12.5	21	33	M12	100
BT 50 MCA12 150 AD+B/2.5G 25000 SL	K10103140173140	50	12.5	21	40	M12	150
BT 50 MCA16 050 AD+B/2.5G 25000 SL	K10103141111230	50	17	29	34	M16	50
BT 50 MCA16 100 AD+B/2.5G 25000 SL	K10103141148140	50	17	29	36	M16	100
BT 50 MCA16 150 AD+B/2.5G 25000 SL	K10103141173140	50	17	29	42.5	M16	150

Note: All Dimensions are in mm



Shrink Fit Holder 4.5 Degree (SFH 4.5°)

◆ Features:

- For Mounting Of Carbide Drills, End Mills etc.
- Easy to Reach at Deep Cavities.
- Best T. I. R. & Rigidity during long working life, Result of in house Reasearch & Development & special Heat Treatment.

◆ Available In Mountings :

- BT (MAS 403) (DIN ISO 7388 - 2)
- BBT (MAS 403)
- SK (DIN 69871) (DIN ISO 7388 - 1)
- HSK-A (DIN 69893-1)
- HSK-F (DIN 69893-6)

◆ Balancing :

- Balanced To 2.5 G 25000 RPM



Maximum Run out of the Internal Dia with respect to the External Taper 0.003 mm

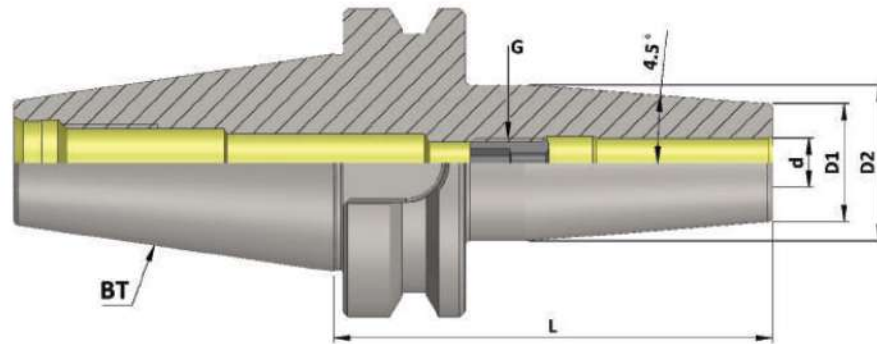

BT (MAS 403) (SFH 4.5°) (AD) JD

(Balanced to 2.5 G 25000 RPM)

Item Name	Item Code	ISO	d	D1	D2	G	L
BT 30 SFH03 080 AD/2.5G 25000 SL	K10101274140129	30	3	10	20	-	80
BT 30 SFH04 080 AD/2.5G 25000 SL	K10101275140129	30	4	15	22	-	80
BT 30 SFH05 080 AD/2.5G 25000 SL	K10101276140129	30	5	15	22	-	80
BT 30 SFH06 080 AD/2.5G 25000 SL	K10101277140129	30	6	21	27	M5	80
BT 30 SFH08 080 AD/2.5G 25000 SL	K10101285140129	30	8	21	27	M6	80
BT 30 SFH10 080 AD/2.5G 25000 SL	K10101279140129	30	10	24	31	M8	80
BT 30 SFH12 080 AD/2.5G 25000 SL	K10101280140129	30	12	24	31	M10	80
BT 30 SFH14 080 AD/2.5G 25000 SL	K10101284140129	30	14	27	34	M10	80
BT 30 SFH16 080 AD/2.5G 25000 SL	K10101281140129	30	16	27	34	M12	80
BT 30 SFH18 080 AD/2.5G 25000 SL	K10101282140129	30	18	33	40	M12	80
BT 30 SFH20 080 AD/2.5G 25000 SL	K10101283140129	30	20	33	40	M16	80

Note: All Dimensions are in mm

Maximum Run out of the Internal Dia with respect to the External Taper 0.003 mm

BT (MAS 403)
DIN ISO 7388 - 2
Holders

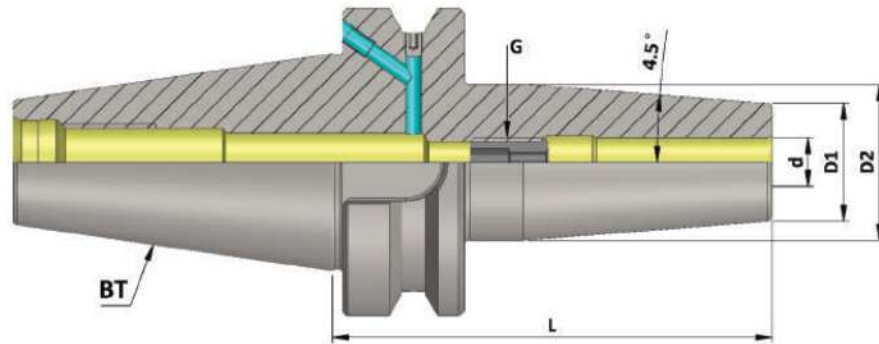

BT (MAS 403) (SFH 4.5°) (AD+B) JD/JF

(Balanced to 2.5 G 25000 RPM)

Item Name	Item Code	ISO	d	D1	D2	G	L
BT 40 SFH03 090 AD+B/2.5G 25000 SL	K10102274140140	40	3	10	20	-	90
BT 40 SFH03 120 AD+B/2.5G 25000 SL	K10102274162140	40	3	10	20	-	120
BT 40 SFH03 160 AD+B/2.5G 25000 SL	K10102274175140	40	3	10	20	-	160
BT 40 SFH04 090 AD+B/2.5G 25000 SL	K10102275140140	40	4	15	22	-	90
BT 40 SFH04 120 AD+B/2.5G 25000 SL	K10102275162140	40	4	15	22	-	120
BT 40 SFH04 160 AD+B/2.5G 25000 SL	K10102275175140	40	4	15	22	-	160
BT 40 SFH05 090 AD+B/2.5G 25000 SL	K10102276140140	40	5	15	22	-	90
BT 40 SFH05 120 AD+B/2.5G 25000 SL	K10102276162140	40	5	15	22	-	120
BT 40 SFH05 160 AD+B/2.5G 25000 SL	K10102276175140	40	5	15	22	-	160
BT 40 SFH06 090 AD+B/2.5G 25000 SL	K10102277140140	40	6	21	27	M5	90
BT 40 SFH06 120 AD+B/2.5G 25000 SL	K10102277162140	40	6	21	27	M5	120
BT 40 SFH06 160 AD+B/2.5G 25000 SL	K10102277175140	40	6	21	27	M5	160
BT 40 SFH08 090 AD+B/2.5G 25000 SL	K10102285140140	40	8	21	27	M6	90
BT 40 SFH08 120 AD+B/2.5G 25000 SL	K10102285162140	40	8	21	27	M6	120
BT 40 SFH08 160 AD+B/2.5G 25000 SL	K10102285175140	40	8	21	27	M6	160
BT 40 SFH10 090 AD+B/2.5G 25000 SL	K10102279140140	40	10	24	31	M8	90
BT 40 SFH10 120 AD+B/2.5G 25000 SL	K10102279162140	40	10	24	31	M8	120
BT 40 SFH10 160 AD+B/2.5G 25000 SL	K10102279175140	40	10	24	31	M8	160
BT 40 SFH12 090 AD+B/2.5G 25000 SL	K10102280140140	40	12	24	31	M10	90
BT 40 SFH12 120 AD+B/2.5G 25000 SL	K10102280162140	40	12	24	31	M10	120
BT 40 SFH12 160 AD+B/2.5G 25000 SL	K10102280175140	40	12	24	31	M10	160

Note: All Dimensions are in mm

Maximum Run out of the Internal Dia with respect to the External Taper 0.003 mm

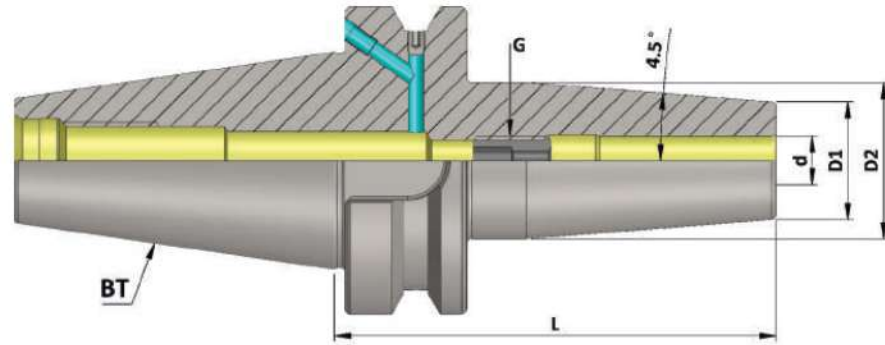

BT (MAS 403) (SFH 4.5°) (AD+B) JD/JF

(Balanced to 2.5 G 25000 RPM)

Item Name	Item Code	ISO	d	D1	D2	G	L
BT 40 SFH14 090 AD+B/2.5G 25000 SL	K10102284140140	40	14	27	34	M10	90
BT 40 SFH14 120 AD+B/2.5G 25000 SL	K10102284162140	40	14	27	34	M10	120
BT 40 SFH14 160 AD+B/2.5G 25000 SL	K10102284175140	40	14	27	34	M10	160
BT 40 SFH16 090 AD+B/2.5G 25000 SL	K10102281140140	40	16	27	34	M12	90
BT 40 SFH16 120 AD+B/2.5G 25000 SL	K10102281162140	40	16	27	34	M12	120
BT 40 SFH16 160 AD+B/2.5G 25000 SL	K10102281175140	40	16	27	34	M12	160
BT 40 SFH18 090 AD+B/2.5G 25000 SL	K10102282140140	40	18	33	40	M12	90
BT 40 SFH18 120 AD+B/2.5G 25000 SL	K10102282162140	40	18	33	40	M12	120
BT 40 SFH18 160 AD+B/2.5G 25000 SL	K10102282175140	40	18	33	40	M12	160
BT 40 SFH20 090 AD+B/2.5G 25000 SL	K10102283140140	40	20	33	40	M16	90
BT 40 SFH20 120 AD+B/2.5G 25000 SL	K10102283162140	40	20	33	40	M16	120
BT 40 SFH20 160 AD+B/2.5G 25000 SL	K10102283175140	40	20	33	40	M16	160
BT 40 SFH25 100 AD+B/2.5G 25000 SL	K10102287148140	40	25	44	53	M16	100
BT 40 SFH25 120 AD+B/2.5G 25000 SL	K10102287162140	40	25	44	53	M16	120
BT 40 SFH25 160 AD+B/2.5G 25000 SL	K10102287175140	40	25	44	53	M16	160
BT 40 SFH32 100 AD+B/2.5G 25000 SL	K10102288148140	40	32	44	53	M16	100
BT 40 SFH32 120 AD+B/2.5G 25000 SL	K10102288162140	40	32	44	53	M16	120
BT 40 SFH32 160 AD+B/2.5G 25000 SL	K10102288175140	40	32	44	53	M16	160

Note: All Dimensions are in mm

Maximum Run out of the Internal Dia with respect to the External Taper 0.003 mm

BT (MAS 403)
DIN ISO 7388 - 2
Holders

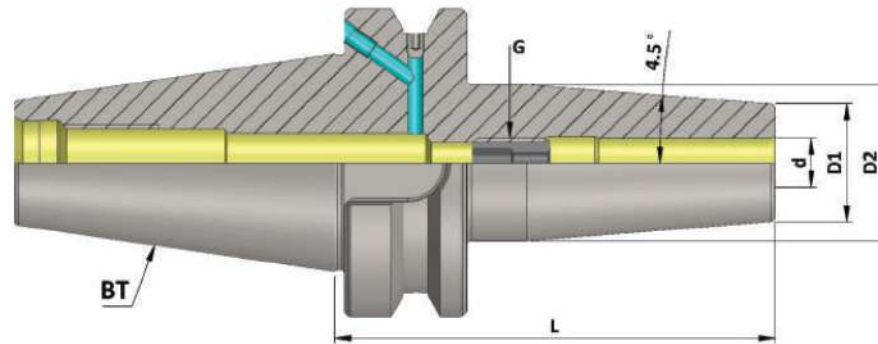

BT (MAS 403) (SFH 4.5°) (AD+B) JD/JF

(Balanced to 2.5 G 25000 RPM)

Item Name	Item Code	ISO	d	D1	D2	G	L
BT 50 SFH03 100 AD+B/2.5G 25000 SL	K10103274148140	50	3	10	20	-	100
BT 50 SFH03 120 AD+B/2.5G 25000 SL	K10103274162140	50	3	10	20	-	120
BT 50 SFH03 160 AD+B/2.5G 25000 SL	K10103274175140	50	3	10	20	-	160
BT 50 SFH04 100 AD+B/2.5G 25000 SL	K10103275148140	50	4	15	22	-	100
BT 50 SFH04 120 AD+B/2.5G 25000 SL	K10103275162140	50	4	15	22	-	120
BT 50 SFH04 160 AD+B/2.5G 25000 SL	K10103275175140	50	4	15	22	-	160
BT 50 SFH05 100 AD+B/2.5G 25000 SL	K10103276148140	50	5	15	22	-	100
BT 50 SFH05 120 AD+B/2.5G 25000 SL	K10103276162140	50	5	15	22	-	120
BT 50 SFH05 160 AD+B/2.5G 25000 SL	K10103276175140	50	5	15	22	-	160
BT 50 SFH06 100 AD+B/2.5G 25000 SL	K10103277148140	50	6	21	27	M5	100
BT 50 SFH06 120 AD+B/2.5G 25000 SL	K10103277162140	50	6	21	27	M5	120
BT 50 SFH06 160 AD+B/2.5G 25000 SL	K10103277175140	50	6	21	27	M5	160
BT 50 SFH08 100 AD+B/2.5G 25000 SL	K10103285148140	50	8	21	27	M6	100
BT 50 SFH08 120 AD+B/2.5G 25000 SL	K10103285162140	50	8	21	27	M6	120
BT 50 SFH08 160 AD+B/2.5G 25000 SL	K10103285175140	50	8	21	27	M6	160
BT 50 SFH10 100 AD+B/2.5G 25000 SL	K10103279148140	50	10	24	31	M8	100
BT 50 SFH10 120 AD+B/2.5G 25000 SL	K10103279162140	50	10	24	31	M8	120
BT 50 SFH10 160 AD+B/2.5G 25000 SL	K10103279175140	50	10	24	31	M8	160
BT 50 SFH12 100 AD+B/2.5G 25000 SL	K10103280148140	50	12	24	31	M10	100
BT 50 SFH12 120 AD+B/2.5G 25000 SL	K10103280162140	50	12	24	31	M10	120
BT 50 SFH12 160 AD+B/2.5G 25000 SL	K10103280175140	50	12	24	31	M10	160

Note: All Dimensions are in mm

Maximum Run out of the Internal Dia with respect to the External Taper 0.003 mm

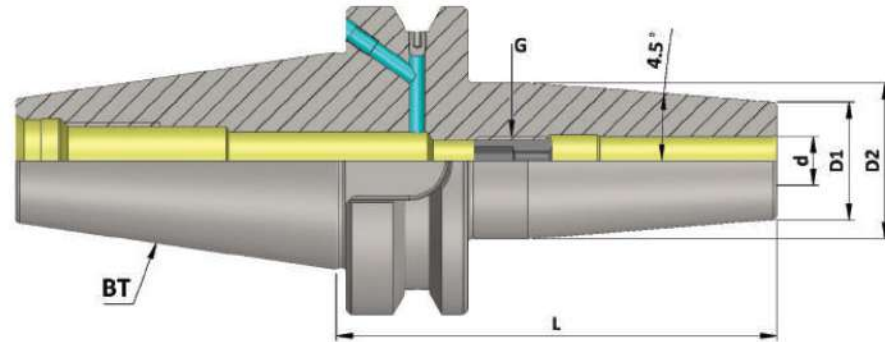

BT (MAS 403) (SFH 4.5°) (AD+B) JD/JF

(Balanced to 2.5 G 25000 RPM)

Item Name	Item Code	ISO	d	D1	D2	G	L
BT 50 SFH14 100 AD+B/2.5G 25000 SL	K10103284148140	50	14	27	34	M10	100
BT 50 SFH14 120 AD+B/2.5G 25000 SL	K10103284162140	50	14	27	34	M10	120
BT 50 SFH14 160 AD+B/2.5G 25000 SL	K10103284175140	50	14	27	34	M10	160
BT 50 SFH16 100 AD+B/2.5G 25000 SL	K10103281148140	50	16	27	34	M12	100
BT 50 SFH16 120 AD+B/2.5G 25000 SL	K10103281162140	50	16	27	34	M12	120
BT 50 SFH16 160 AD+B/2.5G 25000 SL	K10103281175140	50	16	27	34	M12	160
BT 50 SFH18 100 AD+B/2.5G 25000 SL	K10103282148140	50	18	33	40	M12	100
BT 50 SFH18 120 AD+B/2.5G 25000 SL	K10103282162140	50	18	33	40	M12	120
BT 50 SFH18 160 AD+B/2.5G 25000 SL	K10103282175140	50	18	33	40	M12	160
BT 50 SFH20 100 AD+B/2.5G 25000 SL	K10103283148140	50	20	33	40	M16	100
BT 50 SFH20 120 AD+B/2.5G 25000 SL	K10103283162140	50	20	33	40	M16	120
BT 50 SFH20 160 AD+B/2.5G 25000 SL	K10103283175140	50	20	33	40	M16	160
BT 50 SFH25 110 AD+B/2.5G 25000 SL	K10103287156140	50	25	44	53	M16	110
BT 50 SFH25 120 AD+B/2.5G 25000 SL	K10103287162140	50	25	44	53	M16	120
BT 50 SFH25 160 AD+B/2.5G 25000 SL	K10103287175140	50	25	44	53	M16	160
BT 50 SFH32 110 AD+B/2.5G 25000 SL	K10103288156140	50	32	44	53	M16	110
BT 50 SFH32 120 AD+B/2.5G 25000 SL	K10103288162140	50	32	44	53	M16	120
BT 50 SFH32 160 AD+B/2.5G 25000 SL	K10103288175140	50	32	44	53	M16	160

Note: All Dimensions are in mm

Maximum Run out of the Internal Dia with respect to the External Taper 0.003 mm

BT (MAS 403)
DIN ISO 7388 - 2
Holders

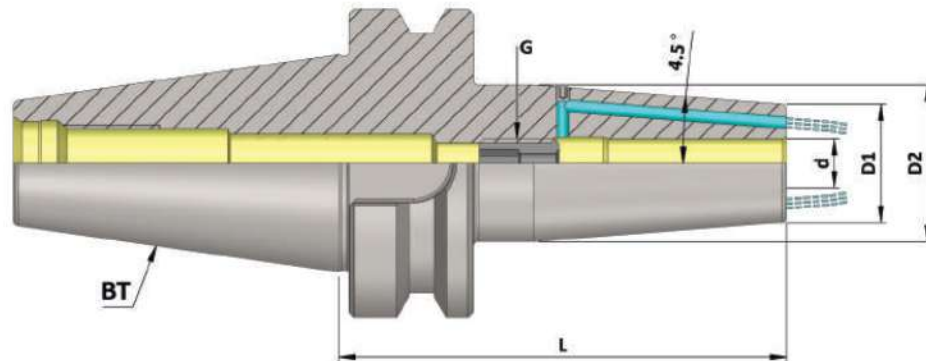

BT (MAS 403) (SFH FCC 4.5°) JD

(Balanced to 2.5 G 25000 RPM)

Item Name	Item Code	ISO	d	D1	D2	G	L
BT 30 SFH03 080 FCC 2.5G 25000 SL	K10101274131256	30	3	10	20	-	80
BT 30 SFH04 080 FCC 2.5G 25000 SL	K10101275131256	30	4	15	22	-	80
BT 30 SFH05 080 FCC 2.5G 25000 SL	K10101276131256	30	5	15	22	-	80
BT 30 SFH06 080 FCC 2.5G 25000 SL	K10101277131256	30	6	21	27	M5	80
BT 30 SFH08 080 FCC 2.5G 25000 SL	K10101285131256	30	8	21	27	M6	80
BT 30 SFH10 080 FCC 2.5G 25000 SL	K10101279131256	30	10	24	31	M8	80
BT 30 SFH12 080 FCC 2.5G 25000 SL	K10101280131256	30	12	24	31	M10	80
BT 30 SFH14 080 FCC 2.5G 25000 SL	K10101284131256	30	14	27	34	M10	80
BT 30 SFH16 080 FCC 2.5G 25000 SL	K10101281131256	30	16	27	34	M12	80
BT 30 SFH18 080 FCC 2.5G 25000 SL	K10101282131256	30	18	33	40	M12	80
BT 30 SFH20 080 FCC 2.5G 25000 SL	K10101283131256	30	20	33	40	M16	80

Note: All Dimensions are in mm

Maximum Run out of the Internal Dia with respect to the External Taper 0.003 mm

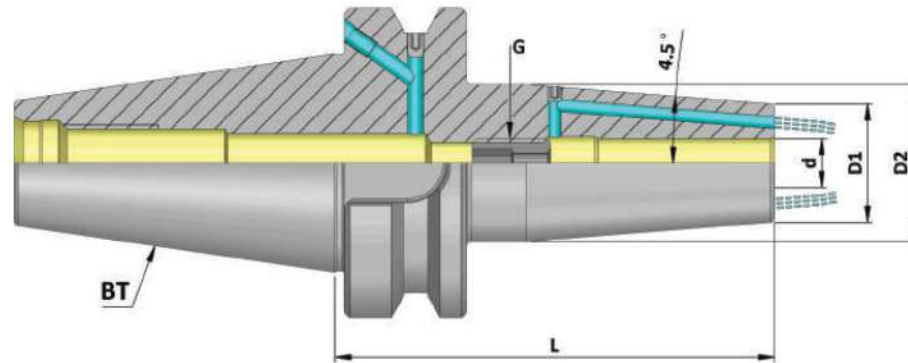

BT (MAS 403) (SFH FCC 4.5°) (AD+B) JD/JF

(Balanced to 2.5 G 25000 RPM)

Item Name	Item Code	ISO	d	D1	D2	G	L
BT40 SFH03 090 FCC AD+B/2.5G 25000 SL	K10102274140255	40	3	10	20	-	90
BT40 SFH03 120 FCC AD+B/2.5G 25000 SL	K10102274162255	40	3	10	20	-	120
BT40 SFH03 160 FCC AD+B/2.5G 25000 SL	K10102274175255	40	3	10	20	-	160
BT40 SFH04 090 FCC AD+B/2.5G 25000 SL	K10102275140255	40	4	15	22	-	90
BT40 SFH04 120 FCC AD+B/2.5G 25000 SL	K10102275162255	40	4	15	22	-	120
BT40 SFH04 160 FCC AD+B/2.5G 25000 SL	K10102275175255	40	4	15	22	-	160
BT40 SFH05 090 FCC AD+B/2.5G 25000 SL	K10102276140255	40	5	15	22	-	90
BT40 SFH05 120 FCC AD+B/2.5G 25000 SL	K10102276162255	40	5	15	22	-	120
BT40 SFH05 160 FCC AD+B/2.5G 25000 SL	K10102276175255	40	5	15	22	-	160
BT40 SFH06 090 FCC AD+B/2.5G 25000 SL	K10102277140255	40	6	21	27	M5	90
BT40 SFH06 120 FCC AD+B/2.5G 25000 SL	K10102277162255	40	6	21	27	M5	120
BT40 SFH06 160 FCC AD+B/2.5G 25000 SL	K10102277175255	40	6	21	27	M5	160
BT40 SFH08 090 FCC AD+B/2.5G 25000 SL	K10102285140255	40	8	21	27	M6	90
BT40 SFH08 120 FCC AD+B/2.5G 25000 SL	K10102285162255	40	8	21	27	M6	120
BT40 SFH08 160 FCC AD+B/2.5G 25000 SL	K10102285175255	40	8	21	27	M6	160
BT40 SFH10 090 FCC AD+B/2.5G 25000 SL	K10102279140255	40	10	24	31	M8	90
BT40 SFH10 120 FCC AD+B/2.5G 25000 SL	K10102279162255	40	10	24	31	M8	120
BT40 SFH10 160 FCC AD+B/2.5G 25000 SL	K10102279175255	40	10	24	31	M8	160
BT40 SFH12 090 FCC AD+B/2.5G 25000 SL	K10102280140255	40	12	24	31	M10	90
BT40 SFH12 120 FCC AD+B/2.5G 25000 SL	K10102280162255	40	12	24	31	M10	120
BT40 SFH12 160 FCC AD+B/2.5G 25000 SL	K10102280175255	40	12	24	31	M10	160

Maximum Run out of the Internal Dia with respect to the External Taper 0.003 mm

BT (MAS 403)
DIN ISO 7388 - 2
Holders

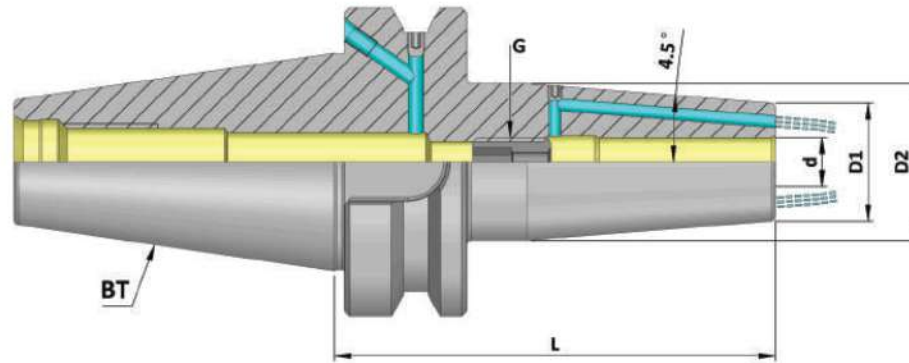

BT (MAS 403) (SFH FCC 4.5°) (AD+B) (JD/JF)

(Balanced to 2.5 G 25000 RPM)

Item Name	Item Code	ISO	d	D1	D2	G	L
BT40 SFH14 090 FCC AD+B/2.5G 25000 SL	K10102284140255	40	14	27	34	M10	90
BT40 SFH14 120 FCC AD+B/2.5G 25000 SL	K10102284162255	40	14	27	34	M10	120
BT40 SFH14 160 FCC AD+B/2.5G 25000 SL	K10102284175255	40	14	27	34	M10	160
BT40 SFH16 090 FCC AD+B/2.5G 25000 SL	K10102281140255	40	16	27	34	M12	90
BT40 SFH16 120 FCC AD+B/2.5G 25000 SL	K10102281162255	40	16	27	34	M12	120
BT40 SFH16 160 FCC AD+B/2.5G 25000 SL	K10102281175255	40	16	27	34	M12	160
BT40 SFH18 090 FCC AD+B/2.5G 25000 SL	K10102282140255	40	18	33	40	M12	90
BT40 SFH18 120 FCC AD+B/2.5G 25000 SL	K10102282162255	40	18	33	40	M12	120
BT40 SFH18 160 FCC AD+B/2.5G 25000 SL	K10102282175255	40	18	33	40	M12	160
BT40 SFH20 090 FCC AD+B/2.5G 25000 SL	K10102283140255	40	20	33	40	M16	90
BT40 SFH20 120 FCC AD+B/2.5G 25000 SL	K10102283162255	40	20	33	40	M16	120
BT40 SFH20 160 FCC AD+B/2.5G 25000 SL	K10102283175255	40	20	33	40	M16	160
BT40 SFH25 100 FCC AD+B/2.5G 25000 SL	K10102287148255	40	25	44	53	M16	100
BT40 SFH25 120 FCC AD+B/2.5G 25000 SL	K10102287162255	40	25	44	53	M16	120
BT40 SFH25 160 FCC AD+B/2.5G 25000 SL	K10102287175255	40	25	44	53	M16	160
BT40 SFH32 100 FCC AD+B/2.5G 25000 SL	K10102288148255	40	32	44	53	M16	100
BT40 SFH32 120 FCC AD+B/2.5G 25000 SL	K10102288162255	40	32	44	53	M16	120
BT40 SFH32 160 FCC AD+B/2.5G 25000 SL	K10102288175255	40	32	44	53	M16	160

Note: All Dimensions are in mm

Maximum Run out of the Internal Dia with respect to the External Taper 0.003 mm

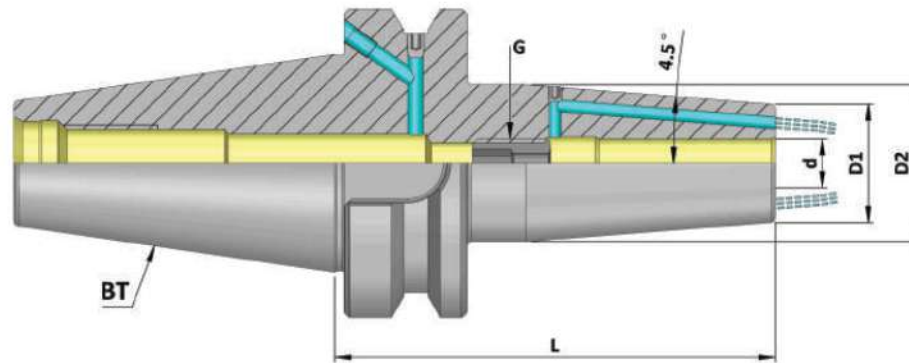

BT (MAS 403) (SFH FCC 4.5°) (AD+B) (JD/JF)

(Balanced to 2.5 G 25000 RPM)

Item Name	Item Code	ISO	d	D1	D2	G	L
BT50 SFH03 100 FCC AD+B/2.5G 25000 SL	K10103274148255	50	3	10	20	-	100
BT50 SFH03 120 FCC AD+B/2.5G 25000 SL	K10103274162255	50	3	10	20	-	120
BT50 SFH03 160 FCC AD+B/2.5G 25000 SL	K10103274175255	50	3	10	20	-	160
BT50 SFH04 100 FCC AD+B/2.5G 25000 SL	K10103275148255	50	4	15	22	-	100
BT50 SFH04 120 FCC AD+B/2.5G 25000 SL	K10103275162255	50	4	15	22	-	120
BT50 SFH04 160 FCC AD+B/2.5G 25000 SL	K10103275175255	50	4	15	22	-	160
BT50 SFH05 100 FCC AD+B/2.5G 25000 SL	K10103276148255	50	5	15	22	-	100
BT50 SFH05 120 FCC AD+B/2.5G 25000 SL	K10103276162255	50	5	15	22	-	120
BT50 SFH05 160 FCC AD+B/2.5G 25000 SL	K10103276175255	50	5	15	22	-	160
BT50 SFH06 100 FCC AD+B/2.5G 25000 SL	K10103277148255	50	6	21	27	M5	100
BT50 SFH06 120 FCC AD+B/2.5G 25000 SL	K10103277162255	50	6	21	27	M5	120
BT50 SFH06 160 FCC AD+B/2.5G 25000 SL	K10103277175255	50	6	21	27	M5	160
BT50 SFH08 100 FCC AD+B/2.5G 25000 SL	K10103285148255	50	8	21	27	M6	100
BT50 SFH08 120 FCC AD+B/2.5G 25000 SL	K10103285162255	50	8	21	27	M6	120
BT50 SFH08 160 FCC AD+B/2.5G 25000 SL	K10103285175255	50	8	21	27	M6	160
BT50 SFH10 100 FCC AD+B/2.5G 25000 SL	K10103279148255	50	10	24	31	M8	100
BT50 SFH10 120 FCC AD+B/2.5G 25000 SL	K10103279162255	50	10	24	31	M8	120
BT50 SFH10 160 FCC AD+B/2.5G 25000 SL	K10103279175255	50	10	24	31	M8	160
BT50 SFH12 100 FCC AD+B/2.5G 25000 SL	K10103280148255	50	12	24	31	M10	100
BT50 SFH12 120 FCC AD+B/2.5G 25000 SL	K10103280162255	50	12	24	31	M10	120
BT50 SFH12 160 FCC AD+B/2.5G 25000 SL	K10103280175255	50	12	24	31	M10	160

Maximum Run out of the Internal Dia with respect to the External Taper 0.003 mm

BT (MAS 403)
DIN ISO 7388 - 2
Holders

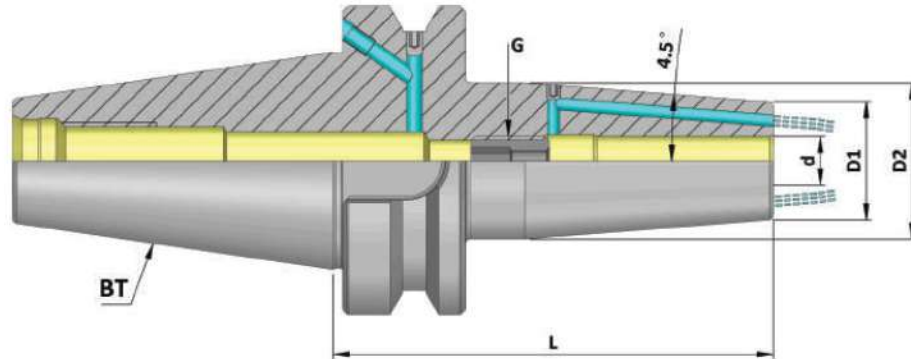

BT (MAS 403) (SFH FCC 4.5°) (AD+B) (JD/JF)

(Balanced to 2.5 G 25000 RPM)

Item Name	Item Code	ISO	d	D1	D2	G	L
BT50 SFH14 100 FCC AD+B/2.5G 25000 SL	K10103284148255	50	14	27	34	M10	100
BT50 SFH14 120 FCC AD+B/2.5G 25000 SL	K10103284162255	50	14	27	34	M10	120
BT50 SFH14 160 FCC AD+B/2.5G 25000 SL	K10103284175255	50	14	27	34	M10	160
BT50 SFH16 100 FCC AD+B/2.5G 25000 SL	K10103281148255	50	16	27	34	M12	100
BT50 SFH16 120 FCC AD+B/2.5G 25000 SL	K10103281162255	50	16	27	34	M12	120
BT50 SFH16 160 FCC AD+B/2.5G 25000 SL	K10103281175255	50	16	27	34	M12	160
BT50 SFH18 100 FCC AD+B/2.5G 25000 SL	K10103282148255	50	18	33	40	M12	100
BT50 SFH18 120 FCC AD+B/2.5G 25000 SL	K10103282162255	50	18	33	40	M12	120
BT50 SFH18 160 FCC AD+B/2.5G 25000 SL	K10103282175255	50	18	33	40	M12	160
BT50 SFH20 100 FCC AD+B/2.5G 25000 SL	K10103283148255	50	20	33	40	M16	100
BT50 SFH20 120 FCC AD+B/2.5G 25000 SL	K10103283162255	50	20	33	40	M16	120
BT50 SFH20 160 FCC AD+B/2.5G 25000 SL	K10103283175255	50	20	33	40	M16	160
BT50 SFH25 110 FCC AD+B/2.5G 25000 SL	K10103287156255	50	25	44	53	M16	110
BT50 SFH25 120 FCC AD+B/2.5G 25000 SL	K10103287162255	50	25	44	53	M16	120
BT50 SFH25 160 FCC AD+B/2.5G 25000 SL	K10103287175255	50	25	44	53	M16	160
BT50 SFH32 110 FCC AD+B/2.5G 25000 SL	K10103288156255	50	32	44	53	M16	110
BT50 SFH32 120 FCC AD+B/2.5G 25000 SL	K10103288162255	50	32	44	53	M16	120
BT50 SFH32 160 FCC AD+B/2.5G 25000 SL	K10103288175255	50	32	44	53	M16	160

Note: All Dimensions are in mm

Maximum Run out of the Internal Dia with respect to the External Taper 0.003 mm

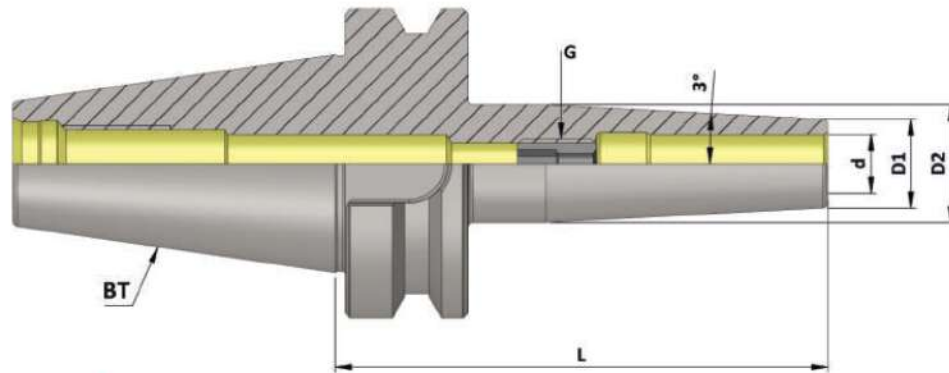

BT (MAS 403) (SFH SLIM 3°) (AD) JD

(Balanced to 2.5 G 25000 RPM)

Item Name	Item Code	ISO	d	D1	D2	G	L
BT30 SFH03 080 SLIM 2.5G 25000 SL	K10101274131258	30	3	9	15	-	80
BT30 SFH03 100 SLIM 2.5G 25000 SL	K10101274148258	30	3	9	18	-	100
BT30 SFH04 080 SLIM 2.5G 25000 SL	K10101275131258	30	4	10	16	-	80
BT30 SFH04 100 SLIM 2.5G 25000 SL	K10101275148258	30	4	10	19	-	100
BT30 SFH05 080 SLIM 2.5G 25000 SL	K10101276131258	30	5	11	17	-	80
BT30 SFH05 100 SLIM 2.5G 25000 SL	K10101276148258	30	5	11	20	-	100
BT30 SFH06 080 SLIM 2.5G 25000 SL	K10101277131258	30	6	12	18	M5	80
BT30 SFH06 100 SLIM 2.5G 25000 SL	K10101277148258	30	6	12	18	M5	100
BT30 SFH08 080 SLIM 2.5G 25000 SL	K10101285131258	30	8	14	20	M6	80
BT30 SFH08 100 SLIM 2.5G 25000 SL	K10101285148258	30	8	14	20	M6	100
BT30 SFH10 080 SLIM 2.5G 25000 SL	K10101279131258	30	10	16	22	M8	80
BT30 SFH10 100 SLIM 2.5G 25000 SL	K10101279148258	30	10	16	22	M8	100
BT30 SFH12 080 SLIM 2.5G 25000 SL	K10101280131258	30	12	18	24	M10	80
BT30 SFH12 100 SLIM 2.5G 25000 SL	K10101280148258	30	12	18	24	M10	100
BT30 SFH14 080 SLIM 2.5G 25000 SL	K10101284131258	30	14	20	26	M10	80
BT30 SFH14 100 SLIM 2.5G 25000 SL	K10101284148258	30	14	20	30	M10	100
BT30 SFH16 080 SLIM 2.5G 25000 SL	K10101281131258	30	16	22	28	M12	80
BT30 SFH16 100 SLIM 2.5G 25000 SL	K10101281148258	30	16	22	32	M12	100
BT30 SFH18 080 SLIM 2.5G 25000 SL	K10101282131258	30	18	24	30	M12	80
BT30 SFH18 100 SLIM 2.5G 25000 SL	K10101282148258	30	18	24	34	M12	100
BT30 SFH20 080 SLIM 2.5G 25000 SL	K10101283131258	30	20	26	32	M16	80
BT30 SFH20 100 SLIM 2.5G 25000 SL	K10101283148258	30	20	26	36	M16	100

Note: All Dimensions are in mm

Maximum Run out of the Internal Dia with respect to the External Taper 0.003 mm

BT (MAS 403)
DIN ISO 7388 - 2
Holders

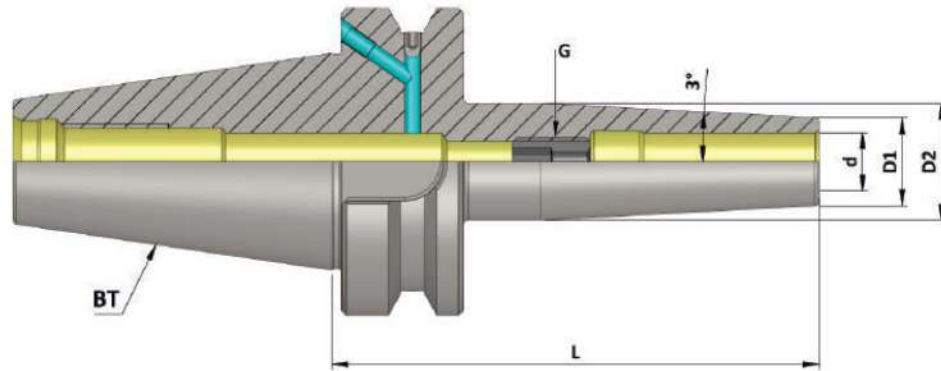

BT (MAS 403) (SFH SLIM 3°) (AD+B) JD/JF

(Balanced to 2.5 G 25000 RPM)

Item Name	Item Code	ISO	d	D1	D2	G	L
BT40 SFH03 090 SLIM AD+B/2.5G 25000 SL	K10102274140259	40	3	9	15	-	90
BT40 SFH03 120 SLIM AD+B/2.5G 25000 SL	K10102274162259	40	3	9	18	-	120
BT40 SFH04 090 SLIM AD+B/2.5G 25000 SL	K10102275140259	40	4	10	16	-	90
BT40 SFH04 120 SLIM AD+B/2.5G 25000 SL	K10102275162259	40	4	10	19	-	120
BT40 SFH05 090 SLIM AD+B/2.5G 25000 SL	K10102276140259	40	5	11	17	-	90
BT40 SFH05 120 SLIM AD+B/2.5G 25000 SL	K10102276162259	40	5	11	20	-	120
BT40 SFH06 090 SLIM AD+B/2.5G 25000 SL	K10102277140259	40	6	12	18	M5	90
BT40 SFH06 120 SLIM AD+B/2.5G 25000 SL	K10102277162259	40	6	12	21	M5	120
BT40 SFH06 160 SLIM AD+B/2.5G 25000 SL	K10102277175259	40	6	12	25	M5	160
BT40 SFH08 090 SLIM AD+B/2.5G 25000 SL	K10102285140259	40	8	14	20	M6	90
BT40 SFH08 120 SLIM AD+B/2.5G 25000 SL	K10102285162259	40	8	14	23	M6	120
BT40 SFH08 160 SLIM AD+B/2.5G 25000 SL	K10102285175259	40	8	14	27	M6	160
BT40 SFH10 090 SLIM AD+B/2.5G 25000 SL	K10102279140259	40	10	16	22	M8	90
BT40 SFH10 120 SLIM AD+B/2.5G 25000 SL	K10102279162259	40	10	16	25	M8	120
BT40 SFH10 160 SLIM AD+B/2.5G 25000 SL	K10102279175259	40	10	16	29	M8	160
BT40 SFH12 090 SLIM AD+B/2.5G 25000 SL	K10102280140259	40	12	18	24	M10	90
BT40 SFH12 120 SLIM AD+B/2.5G 25000 SL	K10102280162259	40	12	18	27	M10	120
BT40 SFH12 160 SLIM AD+B/2.5G 25000 SL	K10102280175259	40	12	18	31	M10	160
BT40 SFH14 090 SLIM AD+B/2.5G25000 SL	K10102284140258	40	14	20	26	M10	90
BT40 SFH14 120 SLIM AD+B/2.5G25000 SL	K10102284162258	40	14	20	29	M10	120
BT40 SFH14 160 SLIM AD+B/2.5G25000 SL	K10102284175258	40	14	20	32	M10	160
BT40 SFH16 090 SLIM AD+B/2.5G25000 SL	K10102281140258	40	16	22	28	M12	90
BT40 SFH16 120 SLIM AD+B/2.5G25000 SL	K10102281162258	40	16	22	31	M12	120
BT40 SFH16 160 SLIM AD+B/2.5G25000 SL	K10102281175258	40	16	22	34	M12	160
BT40 SFH18 090 SLIM AD+B/2.5G25000 SL	K10102282140258	40	18	24	30	M12	90
BT40 SFH18 120 SLIM AD+B/2.5G25000 SL	K10102282162258	40	18	24	33	M12	120
BT40 SFH18 160 SLIM AD+B/2.5G25000 SL	K10102282175258	40	18	24	36	M12	160
BT40 SFH20 090 SLIM AD+B/2.5G25000 SL	K10102283140258	40	20	26	32	M16	90
BT40 SFH20 120 SLIM AD+B/2.5G25000 SL	K10102283162258	40	20	26	35	M16	120
BT40 SFH20 160 SLIM AD+B/2.5G25000 SL	K10102283175258	40	20	26	38	M16	160

Note: All Dimensions are in mm

Maximum Run out of the Internal Dia with respect to the External Taper 0.003 mm

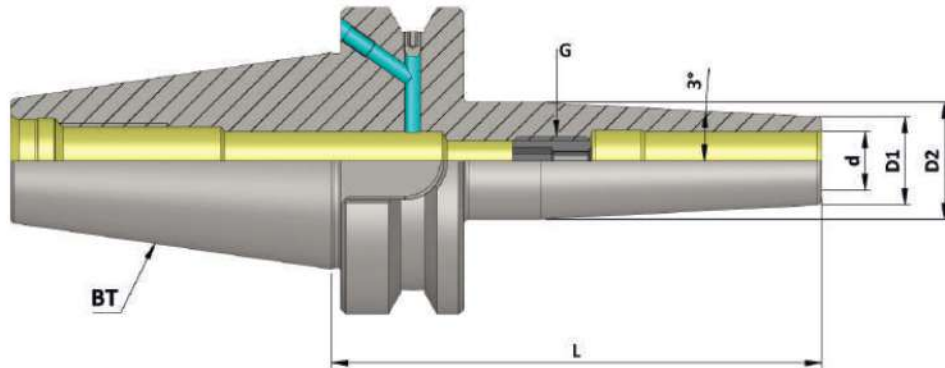

BT (MAS 403)
DIN ISO 7388 - 2
Holders

BT (MAS 403) (SFH SLIM 3°) (AD+B) JD/JF

(Balanced to 2.5 G 25000 RPM)

Item Name	Item Code	ISO	d	D1	D2	G	L
BT50 SFH03 100 SLIM AD+B/2.5G 25000 SL	K10103274148259	50	3	9	15.5	-	100
BT50 SFH03 120 SLIM AD+B/2.5G 25000 SL	K10103274162259	50	3	9	17.5	-	120
BT50 SFH04 100 SLIM AD+B/2.5G 25000 SL	K10103275148259	50	4	10	16.5	-	100
BT50 SFH04 120 SLIM AD+B/2.5G 25000 SL	K10103275162259	50	4	10	18.5	-	120
BT50 SFH05 100 SLIM AD+B/2.5G 25000 SL	K10103276148259	50	5	11	17.5	-	100
BT50 SFH05 120 SLIM AD+B/2.5G 25000 SL	K10103276162259	50	5	11	19.5	-	120
BT50 SFH06 100 SLIM AD+B/2.5G 25000 SL	K10103277148259	50	6	12	18.5	M5	100
BT50 SFH06 120 SLIM AD+B/2.5G 25000 SL	K10103277162259	50	6	12	20.5	M5	120
BT50 SFH06 160 SLIM AD+B/2.5G 25000 SL	K10103277175259	50	6	12	25	M5	160
BT50 SFH08 100 SLIM AD+B/2.5G 25000 SL	K10103285148259	50	8	14	20.5	M6	100
BT50 SFH08 120 SLIM AD+B/2.5G 25000 SL	K10103285162259	50	8	14	22.5	M6	120
BT50 SFH08 160 SLIM AD+B/2.5G 25000 SL	K10103285175259	50	8	14	27	M6	160
BT50 SFH10 100 SLIM AD+B/2.5G 25000 SL	K10103279148259	50	10	16	22.5	M8	100
BT50 SFH10 120 SLIM AD+B/2.5G 25000 SL	K10103279162259	50	10	16	24.5	M8	120
BT50 SFH10 160 SLIM AD+B/2.5G 25000 SL	K10103279175259	50	10	16	29	M8	160
BT50 SFH12 100 SLIM AD+B/2.5G 25000 SL	K10103280148259	50	12	18	24.5	M10	100
BT50 SFH12 120 SLIM AD+B/2.5G 25000 SL	K10103280162259	50	12	18	26.5	M10	120
BT50 SFH12 160 SLIM AD+B/2.5G 25000 SL	K10103280175259	50	12	18	31	M10	160
BT50 SFH14 100 SLIM AD+B/2.5G 25000 SL	K10103284148259	50	14	20	26	M10	100
BT50 SFH14 120 SLIM AD+B/2.5G 25000 SL	K10103284162259	50	14	20	29	M10	120
BT50 SFH14 160 SLIM AD+B/2.5G 25000 SL	K10103284175259	50	14	20	32	M10	160
BT50 SFH16 100 SLIM AD+B/2.5G 25000 SL	K10103281148259	50	16	22	28	M12	100
BT50 SFH16 120 SLIM AD+B/2.5G 25000 SL	K10103281162259	50	16	22	31	M12	120
BT50 SFH16 160 SLIM AD+B/2.5G 25000 SL	K10103281175259	50	16	22	34	M12	160
BT50 SFH18 100 SLIM AD+B/2.5G 25000 SL	K10103282148259	50	18	24	30	M12	100
BT50 SFH18 120 SLIM AD+B/2.5G 25000 SL	K10103282162259	50	18	24	33	M12	120
BT50 SFH18 160 SLIM AD+B/2.5G 25000 SL	K10103282175259	50	18	24	36	M12	160
BT50 SFH20 100 SLIM AD+B/2.5G 25000 SL	K10103283148259	50	20	26	32	M16	100
BT50 SFH20 120 SLIM AD+B/2.5G 25000 SL	K10103283162259	50	20	26	35	M16	120
BT50 SFH20 160 SLIM AD+B/2.5G 25000 SL	K10103283175259	50	20	26	38	M16	160

Note: All Dimensions are in mm

Maximum Run out of the Internal Dia with respect to the External Taper 0.005 mm

BT (MAS 403)
DIN ISO 7388 - 2
Holders

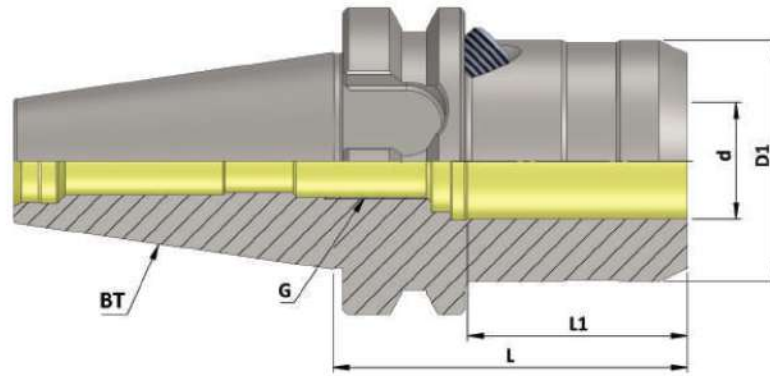

BT(MAS 403) (HC)

(Balanced to 2.5 G 25000 RPM)

Item Name	Item Code	ISO	d	D1	G	L	L1
BT40 HC20S 72.5 AD 2.5 G 25000 SL	K10102168126235	40	20	50	M16x1	72.5	42

Accessories:

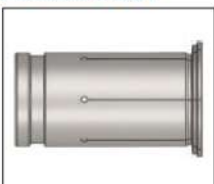

Reduction Sleeve (RS)
Ref. Page No. 242

Note: All Dimensions are in mm

Maximum Run out of the Internal Dia with respect to the External Taper 0.005 mm

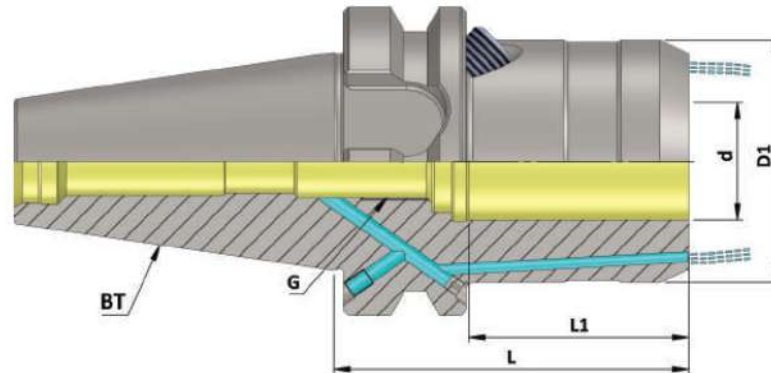

BT (MAS 403)
DIN ISO 7388 - 2
Holders

BT (MAS 403) (HC) (FCC) (AD+B) JD/JF

(Balanced to 2.5 G 25000 RPM)

Item Name	Item Code	ISO	d	D1	G	L	L1
BT30 HC12S 069 FCC AD 2.5G 25000 SL	K10101629135227	30	12	42	M10x1	69	40
BT30 HC20S 090 FCC AD/2.5G 25000 SL	K10101168135129	30	20	50	M16x1	90	42
BT40 HC12S 058 FCC AD+B/2.5G 25000 SL	K10102629140230	40	12	42	M10x1	58	40
BT40 HC20S 72.5 FCC AD+B/2.5G 25000 SL	K10102168126140	40	20	50	M16x1	72.5	42
BT50 HC12S 069 FCC AD+B/2.5G 25000 SL	K10103629338255	50	12	42	M10x1	69	40
BT50 HC20S 083 FCC AD+B/2.5G 25000 SL	K10103168140140	50	20	50	M16x1	83	42
BT50 HC32S 090 FCC AD+B/2.5G 25000 SL	K10103272140140	50	32	72	M16x1	90	55

Accessories:



Reduction Sleeve (RS)
Ref. Page No. 242

Note: All Dimensions are in mm



Minimum Length Compensation Tapping Chuck (MLC)

◆ Features :

- KTA "Minimum Length Compensation Tapping Chuck (MLC)" For Synchronised (Rigid) Tapping Cycle.
- Best suitable for Die & Mould Industry.
- Compression & Expansion +/- 0.5mm
- High Concentricity Enables High Speed Tapping.
- Positive Clamping Through ER Tap Collet.

◆ Technical Details :

- "MLC" Tapping Chucks to be used with CNC Machines, having Synchronised Tapping cycle.
- In this case, Rigid Tapping cycle takes care of tap pitch controlling the feed, spindle speed and feed. So, theoretically, ordinary holder without any compensation also should be suitable for performing the process.
- ◆ But by law of theory, following factors they do affect tapping quality, tap life etc.
 1. Dynamics of machine
 2. Synchronisation of spindle speed & feed.
 3. During Change of Spindle, Rotational direction and feed direction.
 4. Pitch error on Tap / Tolerance on Pitch

◆ This will lead to :

1. Less Tap life because of Flank wear (one side)
 2. Damaged Flanks on threads on the work piece
 3. Threads not answering to Gauge.
- ◆ All above errors can be taken care by using ' MLC '
 - ◆ KTA 'MLC' Tapping Chucks with +/- 0.5 mm compensation.

◆ Available In Following Range :

- ER 16 : M3 to M12
- ER 20 : M3 to M16
- ER 25 : M3 to M20
- ER 32 : M4 to M27
- ER 40 : M6 to M33

◆ Available In Mountings :

- BT (MAS 403) (DIN ISO 7388 - 2)
- BBT (MAS 403)
- SK (DIN 69871) (DIN ISO 7388 - 1)
- HSK - A (DIN 69893-1)
- CAT (ANSI B 5.50)
- Cylindrical Shank

◆ Balancing :

- Main Body Balanced to 2.5G 25000 RPM



Maximum Run out of the Internal Taper with respect to the External Taper 0.020 mm

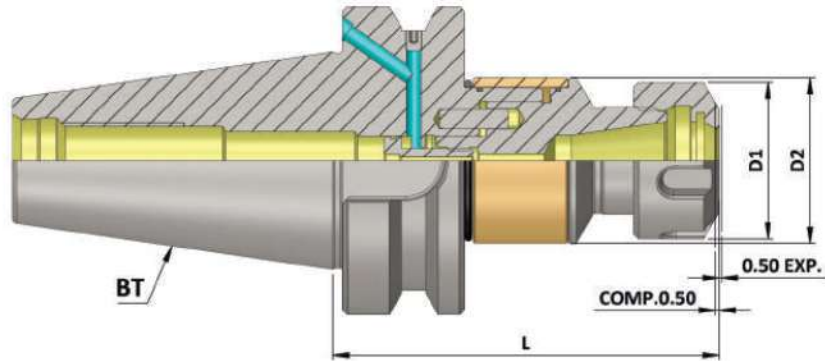

BT (MAS 403) (MLC)

Item Name	Item Code	ISO	Capacity	Clamping Range	Nut Size	D1	D2	L	Comp.	Exp.
BT30 ER 16 079 MLC	K10101149551245	30	M3-M12	1 - 10	ER16	32	34	79	0.5	0.5
BT30 ER 20 080 MLC	K10101150131245	30	M3-M16	3.5 -10	ER20	35	34	80	0.5	0.5
BT 40 ER 16 079 AD+B MLC	K10102149551245	40	M3-M12	1-10	ER 16	32	34	79	0.5	0.5
BT 40 ER 20 085 AD+B MLC	K10102150135250	40	M3-M16	3.5-10	ER 20	35	34	85	0.5	0.5
BT 40 ER 25 089 AD+B MLC	K10102151139245	40	M3-M20	3.5-16	ER 25	42	34	89	0.5	0.5
BT 40 ER 32 110 AD+B MLC	K10102152156245	40	M4-M27	3.5-20	ER 32	50	45	110	0.5	0.5
BT 40 ER 40 115 AD+B MLC	K10102153159245	40	M6-M33	6-26	ER 40	63	62	115	0.5	0.5
BT 50 ER 16 095 AD+B MLC	K10103149145245	50	M3-M12	1-10	ER 16	32	34	95	0.5	0.5
BT 50 ER 20 100 AD+B MLC	K10103150148250	50	M3-M16	3.5-10	ER 20	35	34	100	0.5	0.5
BT 50 ER 25 110 AD+B MLC	K10103151156245	50	M3-M20	3.5-16	ER 25	42	34	110	0.5	0.5
BT 50 ER 32 120 AD+B MLC	K10103152162245	50	M4-M27	3.5-20	ER 32	50	45	120	0.5	0.5
BT 50 ER 40 120 AD+B MLC	K10103153162245	50	M6-M33	6-26	ER 40	63	62	120	0.5	0.5

Accessories:



Tap Collet ER G
Ref. Page No. 238-240



ER Nut
Ref. Page No. 220-221



Q.C. Tap Collet QCTC
Ref. Page No. 243-251



ER Spanner
Ref. Page No. 222

Note: All Dimensions are in mm



Quick Change Tapping Chuck (KWFLK)

KWFLK For CNC Machines

◆ **Application :**

- Most Suitable Tapping Chuck for CNC Machines, Manual Drilling Machines, Lathe Machines & Milling machines.

◆ **Features:**

- Quick Change feature to suit KTA - Quick Change Adaptors with and without safety clutch.
- Length compensation to compensate difference in pitch between positive feed and the pitch of the tap.
- The chuck is equipped with an adjustable device to increase the cutting pressure to ensure positive start when tapping cycle commences.
- Chucks WFLK can be applied horizontal or vertical and are used for right or left hand threads.

◆ **Available In Mountings :**

- BT (MAS 403) (DIN ISO 7388 - 2)
- BBT (MAS 403)
- SK (DIN 69871) (DIN ISO 7388 - 1)
- HSK-A (DIN 69893-1)
- CAT (ANSI B 5.50)
- HSK-F (DIN 6989-1)
- Cylindrical Shank
- Morse Taper Shank

◆ **Available In Sizes :**

- KWFLK1
- KWFLK2
- KWFLK3
- KWFLK4



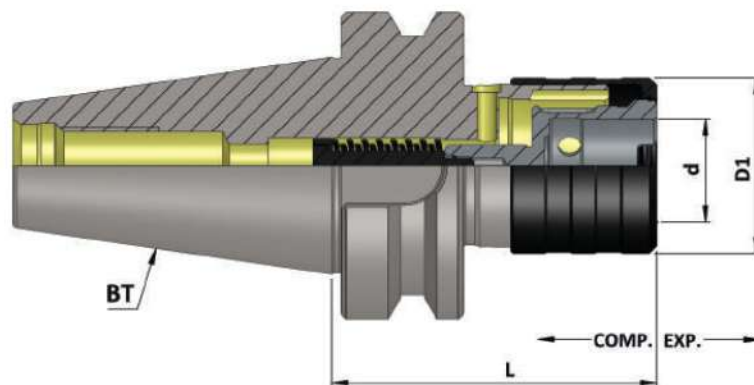

BT (MAS 403)
DIN ISO 7388 - 2
Holders

BT (MAS 403) (KWFLK)

Item Name	Item Code	ISO	Capacity	Suitable Adaptor	Comp.	Exp.	d	D1	L
BT 30 KWFLK1 64.0	K10101169278127	30	M3-M12	KWES1B	7.50	7.50	19	36	64
BT 40 KWFLK1 67.5	K10102169124127	40	M3-M12	KWES1B	7.50	7.50	19	36	67.5
BT 40 KWFLK2 94.5	K10102170144127	40	M8-M20	KWES2B	12.50	12.50	31	53	94.5
BT 40 KWFLK3 164.5	K10102171176127	40	M14-M33	KWES3B	20.00	20.00	48	78	164.5
BT 40 KWFLK4 180.0	K10102172478127	40	M22-M48	KWES4B	22.50	22.50	60	96	180.0
BT 50 KWFLK1 77.0	K10103169279127	50	M3-M12	KWES1B	7.50	7.50	19	36	77
BT 50 KWFLK2 102.5	K10103170280127	50	M8-M20	KWES2B	12.50	12.50	31	53	102.5
BT 50 KWFLK3 142.5	K10103171171127	50	M14-M33	KWES3B	20.00	20.00	48	78	142.5
BT 50 KWFLK4 164.5	K10103172176127	50	M22-M48	KWES4B	22.50	22.50	60	96	164.5

Accessories:



Tap Adaptor KWES..B & KWESK..B
Ref. Page No. 260-279



Tap Adaptor
Reduction Socket KWRE
Ref. Page No. 280

Note: • All Dimensions are in mm
• For Tap Shank Dimension & Recommended Torque Values Ref. Page No. 281-284