



KTA SPINDLE TOOLINGS

A Tool Holder Company

www.ktaspindletoolings.com



Check Stock @ Link
<http://119.81.67.54/CRMWebsite/ViewCurrentStockPosition.aspx>
And send enquiry to the nearest dealer.

2019



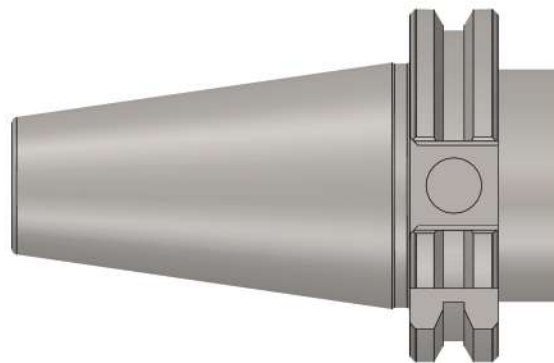





**Precision Tool Holders
SK - DIN ISO 7388 - 1
(DIN 69871)**



INDEX

Sr. No.	Contents		Page No.
①	Technical Information: SK - DIN ISO 7388 - 1 (DIN 69871)		101
②	Collet Chuck ER (DIN 6499) <ul style="list-style-type: none"> • Collet Chuck ER (AD) DIN ISO 7388 - 1 AD • Collet Chuck ER (AD+B) DIN ISO 7388 - 1 AD/AF • Collet Chuck ER "M" Type (AD+B) DIN ISO 7388 - 1 AD/AF • Collet Chuck ER "A" Type (Short GP) 		102 - 105
③	Weldon Type End Mill Holders (DIN 6359) <ul style="list-style-type: none"> • Weldon (WE) (AD) DIN ISO 7388 - 1 AD • Weldon (WE) FCC (AD+B) DIN ISO 7388 - 1 AD/AF 		106 - 109
④	Face Mill Holders (DIN 6357) <ul style="list-style-type: none"> • FMH (AD) DIN ISO 7388 - 1 AD • FMH-K Through Coolant (AD+B) DIN ISO 7388 - 1 AD/AF 		110 - 111
⑤	Combi Shell Mill Adaptor (CSMA) (DIN 6358)		112
⑥	Morse Taper Adaptor (MTA) (DIN 6383)		113
⑦	Reduction Sleeve (SK50 x SK40)		114
⑧	Boring Bar Blank		115
⑨	Master Mandrell		116
⑩	NC Drill Chuck (NCDC)		117

INDEX

Sr. No.	Contents		Page No.
11	Die & Mould Chuck (DMC)		118 - 119
12	Power Milling Chuck (PMC)		120 - 121
13	Milling Cutter Arbor (MCA)		122 - 124
14	Shrink Fit Holders 4.5 Degree (SFH 4.5°) <ul style="list-style-type: none"> • Shrink Fit Holder (SFH 4.5°) (AD+B) DIN ISO 7388 - 1 AD/AF • Shrink Fit Holder (SFH FCC 4.5°) (AD+B) DIN ISO 7388 - 1 AD/AF (Face Coolant Channel) 		125 - 132
15	Shrink Fit Holders Slim 3 Degree (SFH Slim 3°) <ul style="list-style-type: none"> • Shrink Fit Holder (SFH Slim 3°) (AD+B) DIN ISO 7388 - 1 AD/AF 		133 - 134
16	Hydraulic Expansion Chuck (HC)		135
17	Minimum Length Compensation Tapping Chuck (MLC)		136 - 137
18	Quick Change Tapping Chuck (KWFLK)		138 - 139

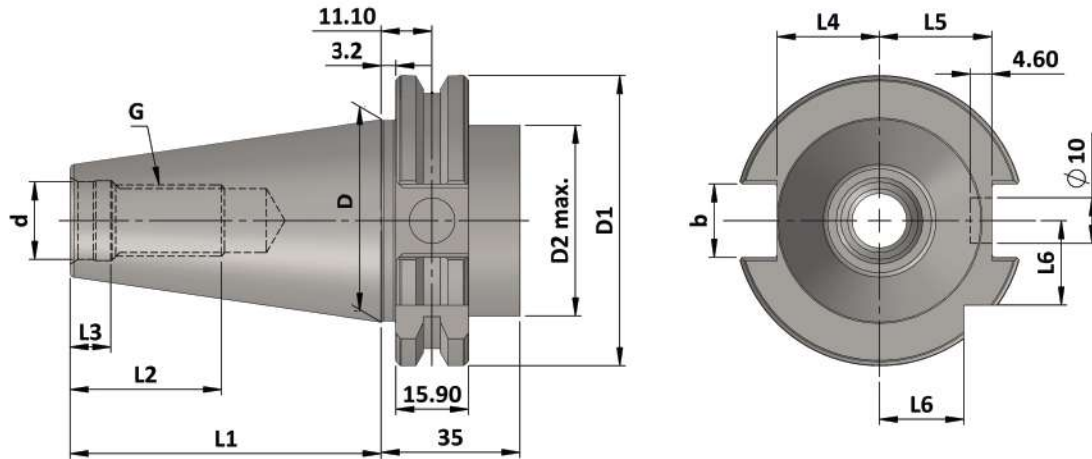

SK	d	d1	D	D1	D2	e	b	G	L1	L2	L3	L4	L5	L6
30	13	4	31.75	50.00	45	21	16.1	M12	47.80	24	5.5	16.4	19.0	15.00
40	17	4	44.45	63.55	50	27	16.1	M16	68.40	32	8.2	22.80	25.0	18.50
50	25	6	69.85	97.50	80	42	25.7	M24	101.75	47	11.5	35.5	37.7	30.00

Material :- Case hardened steel, tensile strength in the core min. 950 N/mm²

Execution :- Case hardened to HRC 58 ± 2, Case Depth 0.8 mm., Silver finish.

Accuracy :- 7:24 Taper Angle Class AT 3 As per DIN 2080

Old Name : SK (DIN 69871) AD
New Name : SK (DIN 69871) DIN ISO 7388-1 AD
(Coolant Supply Through Center)

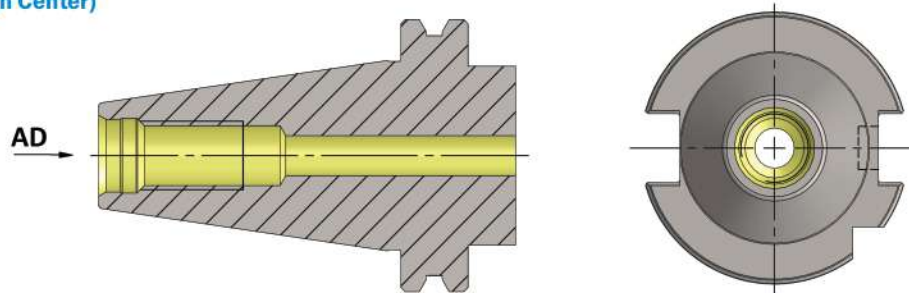

Old Name : SK (DIN 69871) AD+ B
New Name : SK (DIN 69871) DIN ISO 7388-1 AD / AF
(Coolant Supply Through Flange)

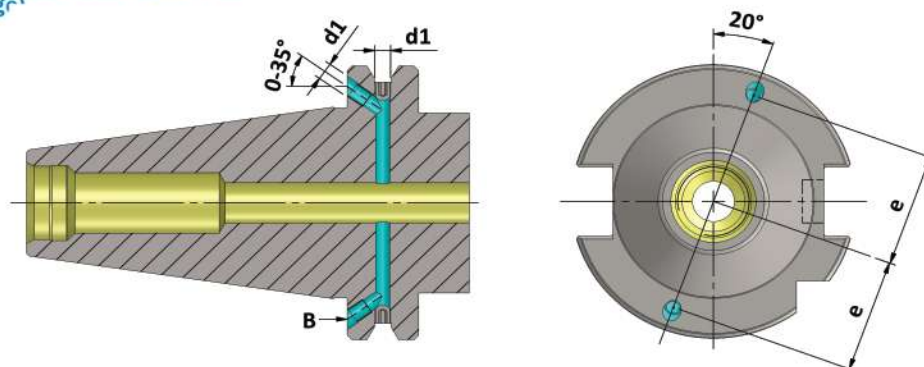

Note: All Dimensions are in mm

Maximum Run out of the Internal Taper with respect to the External Taper 0.005 mm

SK (DIN 69871)
DIN ISO 7388 - 1
Holders

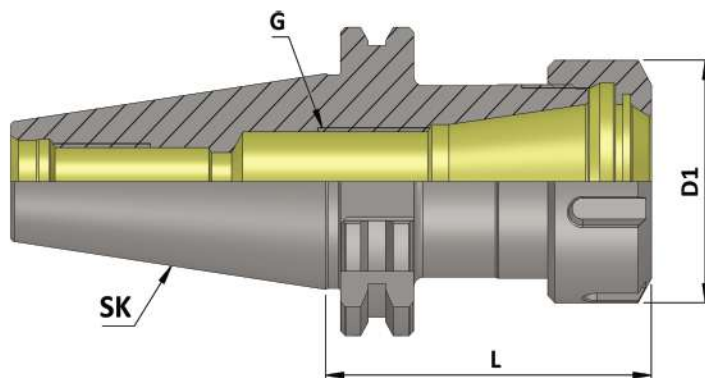
SK (DIN 69871) Collet Chuck ER (AD)

(Balanced to 6.3 G 15000 RPM)

Item Name	Item Code	SK	Suitable Collet	Collet Capacity	D1	G	L	Nut	Spanner
SK 40 ER 16 070 AD/6.3G15000 SL	K10104149125110	40	ER 16	0.5-10	32	M10X1	70	UM/ER16	E16
SK 40 ER 16 100 AD/6.3G15000 SL	K10104149148110	40	ER 16	0.5-10	32	M10X1	100	UM/ER16	E16
SK 40 ER 16 160 AD/6.3G15000 SL	K10104149175110	40	ER 16	0.5-10	32	M10X1	160	UM/ER16	E16
SK 40 ER 20 070 AD/6.3G15000 SL	K10104150125110	40	ER 20	1.0-13	35	M10X1	70	UM/ER20	E20
SK 40 ER 20 100 AD/6.3G15000 SL	K10104150148110	40	ER 20	1.0-13	35	M10X1	100	UM/ER20	E20
SK 40 ER 20 160 AD/6.3G15000 SL	K10104150175110	40	ER 20	1.0-13	35	M10X1	160	UM/ER20	E20
SK 40 ER 25 070 AD/6.3G15000 SL	K10104151125110	40	ER 25	1.0-16	42	M18X1	70	UM/ER25	E25
SK 40 ER 25 100 AD/6.3G15000 SL	K10104151148110	40	ER 25	1.0-16	42	M18X1	100	UM/ER25	E25
SK 40 ER 25 160 AD/6.3G15000 SL	K10104151175110	40	ER 25	1.0-16	42	M18X1	160	UM/ER25	E25
SK 40 ER 32 070 AD/6.3G15000 SL	K10104152125110	40	ER 32	2.0-20	50	M22X1.5	70	UM/ER32	E32
SK 40 ER 32 100 AD/6.3G15000 SL	K10104152148110	40	ER 32	2.0-20	50	M22X1.5	100	UM/ER32	E32
SK 40 ER 32 160 AD/6.3G15000 SL	K10104152175110	40	ER 32	2.0-20	50	M22X1.5	160	UM/ER32	E32
SK 40 ER 40 070 AD/6.3G15000 SL	K10104153125110	40	ER 40	3.0-26	63	M30X1.5	70	UM/ER40	E40
SK 40 ER 40 100 AD/6.3G15000 SL	K10104153148110	40	ER 40	3.0-26	63	M30X1.5	100	UM/ER40	E40
SK 40 ER 40 160 AD/6.3G15000 SL	K10104153175110	40	ER 40	3.0-26	63	M30X1.5	160	UM/ER40	E40
SK 40 ER 50 100 AD/6.3G15000 SL	K10104154148110	40	ER 50	10-34	78	M16X2	100	UM/ER50	E50

SK 50 ER 16 070 AD/6.3G15000 SL	K10105149125110	50	ER 16	0.5-10	32	M10X1	70	UM/ER16	E16
SK 50 ER 16 100 AD/6.3G15000 SL	K10105149148110	50	ER 16	0.5-10	32	M10X1	100	UM/ER16	E16
SK 50 ER 16 160 AD/6.3G15000 SL	K10105149175110	50	ER 16	0.5-10	32	M10X1	160	UM/ER16	E16
SK 50 ER 25 070 AD/6.3G15000 SL	K10105151125110	50	ER 25	1.0-16	42	M18X1	70	UM/ER25	E25
SK 50 ER 25 100 AD/6.3G15000 SL	K10105151148110	50	ER 25	1.0-16	42	M18X1	100	UM/ER25	E25
SK 50 ER 25 160 AD/6.3G15000 SL	K10105151175110	50	ER 25	1.0-16	42	M18X1	160	UM/ER25	E25
SK 50 ER 32 070 AD/6.3G15000 SL	K10105152125110	50	ER 32	2.0-20	50	M22X1.5	70	UM/ER32	E32
SK 50 ER 32 100 AD/6.3G15000 SL	K10105152148110	50	ER 32	2.0-20	50	M22X1.5	100	UM/ER32	E32
SK 50 ER 32 160 AD/6.3G15000 SL	K10105152175110	50	ER 32	2.0-20	50	M22X1.5	160	UM/ER32	E32
SK 50 ER 40 080 AD/6.3G15000 SL	K10105153131110	50	ER 40	3.0-26	63	M30X1.5	80	UM/ER40	E40
SK 50 ER 40 100 AD/6.3G15000 SL	K10105153148110	50	ER 40	3.0-26	63	M30X1.5	100	UM/ER40	E40
SK 50 ER 40 160 AD/6.3G15000 SL	K10105153175110	50	ER 40	3.0-26	63	M30X1.5	160	UM/ER40	E40
SK 50 ER 50 100 AD/6.3G15000 SL	K10105154148110	50	ER 50	10-34	78	M16X2	100	UM/ER50	E50
SK 50 ER 50 160 AD/6.3G15000 SL	K10105154175110	50	ER 50	10-34	78	M16X2	160	UM/ER50	E50

Note: All Dimensions are in mm

Maximum Run out of the Internal Taper with respect to the External Taper 0.005 mm

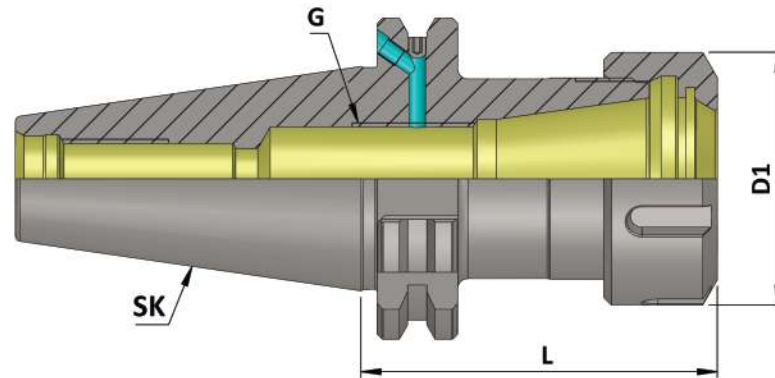

SK (DIN 69871)
DIN ISO 7388 - 1
Holders

SK (DIN 69871) Collet Chuck ER (AD+B) AD/AF

(Balanced to 6.3 G 15000 RPM)

Item Name	Item Code	SK	Suitable Collet	Collet Capacity	D1	G	L	Nut	Spanner
SK 40 ER 16 070 AD+B/6.3G15000 SL	K10104149125112	40	ER 16	0.5-10	32	M10X1	70	UM/ER16	E16
SK 40 ER 16 100 AD+B/6.3G15000 SL	K10104149148112	40	ER 16	0.5-10	32	M10X1	100	UM/ER16	E16
SK 40 ER 16 160 AD+B/6.3G15000 SL	K10104149175112	40	ER 16	0.5-10	32	M10X1	160	UM/ER16	E16
SK 40 ER 20 070 AD+B/6.3G15000 SL	K10104150125112	40	ER 20	1.0-13	35	M10X1	70	UM/ER20	E20
SK 40 ER 20 100 AD+B/6.3G15000 SL	K10104150148112	40	ER 20	1.0-13	35	M10X1	100	UM/ER20	E20
SK 40 ER 20 160 AD+B/6.3G15000 SL	K10104150175112	40	ER 20	1.0-13	35	M10X1	160	UM/ER20	E20
SK 40 ER 25 070 AD+B/6.3G15000 SL	K10104151125112	40	ER 25	1.0-16	42	M18X1	70	UM/ER25	E25
SK 40 ER 25 100 AD+B/6.3G15000 SL	K10104151148112	40	ER 25	1.0-16	42	M18X1	100	UM/ER25	E25
SK 40 ER 25 160 AD+B/6.3G15000 SL	K10104151175112	40	ER 25	1.0-16	42	M18X1	160	UM/ER25	E25
SK 40 ER 32 070 AD+B/6.3G15000 SL	K10104152125112	40	ER 32	2.0-20	50	M22X1.5	70	UM/ER32	E32
SK 40 ER 32 100 AD+B/6.3G15000 SL	K10104152148112	40	ER 32	2.0-20	50	M22X1.5	100	UM/ER32	E32
SK 40 ER 32 160 AD+B/6.3G15000 SL	K10104152175112	50	ER 32	2.0-20	50	M22X1.5	160	UM/ER32	E32
SK 40 ER 40 070 AD+B/6.3G15000 SL	K10104153125112	40	ER 40	3.0-26	63	M30X1.5	70	UM/ER40	E40
SK 40 ER 40 100 AD+B/6.3G15000 SL	K10104153148112	40	ER 40	3.0-26	63	M30X1.5	100	UM/ER40	E40
SK 40 ER 40 160 AD+B/6.3G15000 SL	K10104153175112	40	ER 40	3.0-26	63	M30X1.5	160	UM/ER40	E40
SK 40 ER 50 100 AD+B/6.3G15000 SL	K10104154148112	40	ER 50	10-34	78	M16X2P	100	UM/ER50	E50

SK 50 ER 16 070 AD+B/6.3G15000 SL	K10105149125112	50	ER 16	0.5-10	32	M10X1	70	UM/ER16	E16
SK 50 ER 16 100 AD+B/6.3G15000 SL	K10105149148112	50	ER 16	0.5-10	32	M10X1	100	UM/ER16	E16
SK 50 ER 16 160 AD+B/6.3G15000 SL	K10105149175112	50	ER 16	0.5-10	32	M10X1	160	UM/ER16	E16
SK 50 ER 25 070 AD+B/6.3G15000 SL	K10105151125112	50	ER 25	1.0-16	42	M18X1	70	UM/ER25	E25
SK 50 ER 25 100 AD+B/6.3G15000 SL	K10105151148112	50	ER 25	1.0-16	42	M18X1	100	UM/ER25	E25
SK 50 ER 25 160 AD+B/6.3G15000 SL	K10105151175112	50	ER 25	1.0-16	42	M18X1	160	UM/ER25	E25
SK 50 ER 32 070 AD+B/6.3G15000 SL	K10105152125112	50	ER 32	2.0-20	50	M22X1.5	70	UM/ER32	E32
SK 50 ER 32 100 AD+B/6.3G15000 SL	K10105152148112	50	ER 32	2.0-20	50	M22X1.5	100	UM/ER32	E32
SK 50 ER 32 160 AD+B/6.3G15000 SL	K10105152175112	50	ER 32	2.0-20	50	M22X1.5	160	UM/ER32	E32
SK 50 ER 40 080 AD+B/6.3G15000 SL	K10105153131112	50	ER 40	3.0-26	63	M30X1.5	80	UM/ER40	E40
SK 50 ER 40 100 AD+B/6.3G15000 SL	K10105153148112	50	ER 40	3.0-26	63	M30X1.5	100	UM/ER40	E40
SK 50 ER 40 160 AD+B/6.3G15000 SL	K10105153175112	50	ER 40	3.0-26	63	M30X1.5	160	UM/ER40	E40
SK 50 ER 50 100 AD+B/6.3G15000 SL	K10105154148112	50	ER 50	10-34	78	M16X2	100	UM/ER50	E50
SK 50 ER 50 160 AD+B/6.3G15000 SL	K10105154175112	50	ER 50	10-34	78	M16X2	160	UM/ER50	E50

Note: All Dimensions are in mm
For Necessary Accessories Selection Please Go Through Page No. 104

Maximum Run out of the Internal Taper with respect to the External Taper 0.005 mm

SK (DIN 69871)
DIN ISO 7388 - 1
Holders

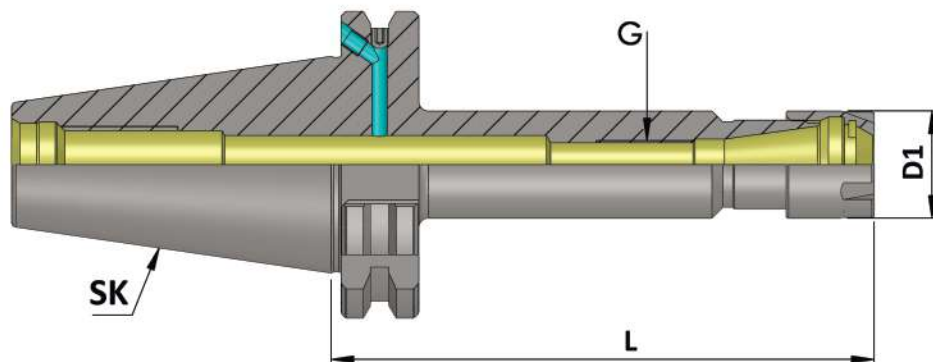

SK (DIN 69871) Collet Chuck ER M Type (AD+B) AD/AF

(Balanced to 2.5 G 25000 RPM)

Item Name	Item Code	SK	Suitable Collet	Collet Capacity	D1	G	L	Nut	Spanner
SK 40 ER11M 050 AD+B/2.5G 25000 SL	K10104156111230	40	ER 11	0.5-7	16	M6X1	50	ER11M	E11M
SK 40 ER11M 100 AD+B/2.5G 25000 SL	K10104156148230	40	ER 11	0.5-7	16	M6X1	100	ER11M	E11M
SK 40 ER11M 160 AD+B/2.5G 25000 SL	K10104156175230	40	ER 11	0.5-7	16	M6X1	160	ER11M	E11M
SK 40 ER16M 070 AD+B/2.5G 25000 SL	K10104157125230	40	ER 16	0.5-10	22	M10X1	70	ER16M	E16M
SK 40 ER16M 100 AD+B/2.5G 25000 SL	K10104157148140	40	ER 16	0.5-10	22	M10X1	100	ER16M	E16M
SK 40 ER16M 160 AD+B/2.5G 25000 SL	K10104157175230	40	ER 16	0.5-10	22	M10X1	160	ER16M	E16M
SK 40 ER25M 070 AD+B/2.5G 25000 SL	K10104159125230	40	ER 25	1.0-16	35	M18X1	70	ER25M	E25M
SK 40 ER25M 100 AD+B/2.5G 25000 SL	K10104159148230	40	ER 25	1.0-16	35	M18X1	100	ER25M	E25M
SK 40 ER25M 160 AD+B/2.5G 25000 SL	K10104159175230	40	ER 25	1.0-16	35	M18X1	160	ER25M	E25M

Accessories:



Collet ER (DIN 6499)
Ref. Page No. 233-237



Tap Collet ER-G
Ref. Page No. 238-240



Q.C.Tap Collet QCTC
Ref. Page No. 243-251



Sealing Disc
Ref. Page No. 226-231



ER Nut & ER Sealed Nut & ER M Nut
Ref. Page No. 220-221
& 224-225

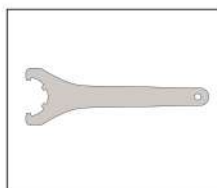

ER Spanner
Ref. Page No. 222

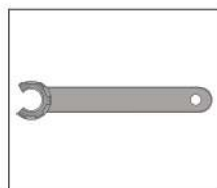

ER M Type Spanner
Ref. Page No. 222

Note: All Dimensions are in mm

Maximum Run out of the Internal Taper with respect to the External Taper 0.005 mm

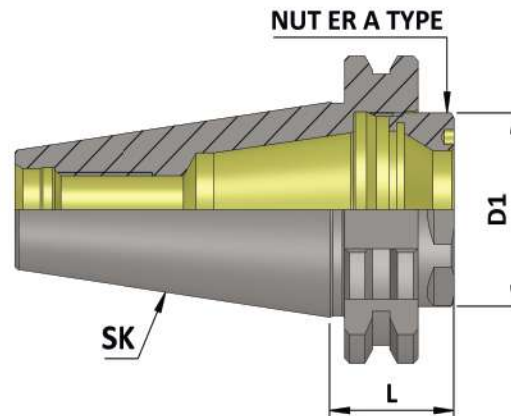

SK (DIN 69871)
DIN ISO 7388 - 1
Holders

SK (DIN 69871) Short GP Collect Chuck ER-A

(Balanced to 6.3 G 15000 RPM)

Item Name	Item Code	SK	Suitable Collet	Collet Capacity	D1	L	NUT
SK 40 ER 32A 24 AD/6.3G15000 SL	K10104244248110	40	ER 32	2-20	40	24	ER32A
SK 50 ER 32A 24 AD/6.3G15000 SL	K10105244248110	50	ER 32	2-20	40	24	ER32A

Accessories:

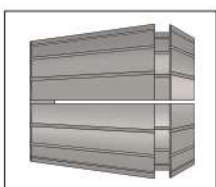

Collet ER (DIN 6499)
Ref. Page No. 233-237



Tap Collet ER-G
Ref. Page No. 238-240



Q.C.Tap Collet (QCTC)
Ref. Page No. 243-251



ER A Nut
Ref. Page No. 220-221

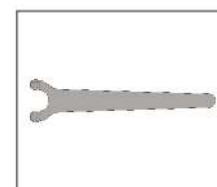

ER A Spanner
Ref. Page No. 222

Note: All Dimensions are in mm

Maximum Run out of the Internal Dia with respect to the External Taper 0.005 mm

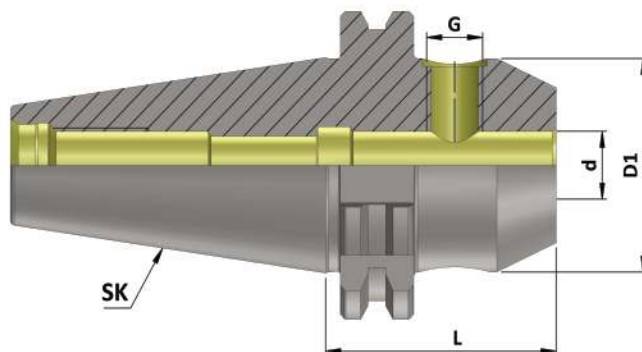

SK (DIN 69871)
 DIN ISO 7388 - 1
 Holders

SK (DIN 69871) (WE) (AD)

(Balanced to 6.3 G 15000 RPM)

Item Name	Item Code	SK	d	D1	G	L	Screw Qty.
SK 40 WE06 050 AD/6.3G15000 SL	K10104111111110	40	6	25	M6	50	1
SK 40 WE06 100 AD/6.3G15000 SL	K10104111148110	40	6	25	M6	100	1
SK 40 WE06 160 AD/6.3G15000 SL	K10104111175110	40	6	25	M6	160	1
SK 40 WE08 050 AD/6.3G15000 SL	K10104112111110	40	8	28	M8	50	1
SK 40 WE08 100 AD/6.3G15000 SL	K10104112148110	40	8	28	M8	100	1
SK 40 WE08 160 AD/6.3G15000 SL	K10104112175110	40	8	28	M8	160	1
SK 40 WE10 050 AD/6.3G15000 SL	K10104113111110	40	10	35	M10	50	1
SK 40 W 10 100 AD/6.3G15000 SL	K10104113148110	40	10	35	M10	100	1
SK 40 WE10 160 AD/6.3G15000 SL	K10104113175110	40	10	35	M10	160	1
SK 40 WE12 050 AD/6.3G15000 SL	K10104114111110	40	12	42	M12	50	1
SK 40 WE12 100 AD/6.3G15000 SL	K10104114148110	40	12	42	M12	100	1
SK 40 WE12 160 AD/6.3G15000 SL	K10104114175110	40	12	42	M12	160	1
SK 40 WE14 050 AD/6.3G15000 SL	K10104258111110	40	14	44	M12	50	1
SK 40 WE14 100 AD/6.3G15000 SL	K10104258148110	40	14	44	M12	100	1
SK 40 WE14 160 AD/6.3G15000 SL	K10104258175110	40	14	44	M12	160	1
SK 40 WE16 063 AD/6.3G15000 SL	K10104115119110	40	16	48	M14	63	1
SK 40 WE16 100 AD/6.3G15000 SL	K10104115148110	40	16	48	M14	100	1
SK 40 WE16 160 AD/6.3G15000 SL	K10104115175110	40	16	48	M14	160	1
SK 40 WE18 063 AD/6.3G15000 SL	K10104259119110	40	18	50	M14	63	1
SK 40 WE18 100 AD/6.3G15000 SL	K10104259148110	40	18	50	M14	100	1
SK 40 WE18 160 AD/6.3G15000 SL	K10104259175110	40	18	50	M14	160	1
SK 40 WE20 063 AD/6.3G15000 SL	K10104116119110	40	20	52	M16	63	1
SK 40 WE20 100 AD/6.3G15000 SL	K10104116148110	40	20	52	M16	100	1
SK 40 WE20 160 AD/6.3G15000 SL	K10104116175110	40	20	52	M16	160	1
SK 40 WE25 100 AD/6.3G15000 SL	K10104117148110	40	25	65	M18X2	100	2
SK 40 WE25 160 AD/6.3G15000 SL	K10104117175110	40	25	65	M18X2	160	2
SK 40 WE32 100 AD/6.3G15000 SL	K10104118148110	40	32	72	M20X2	100	2
SK 40 WE32 160 AD/6.3G15000 SL	K10104118175110	40	32	72	M20X2	160	2
SK 40 WE40 115 AD/6.3G15000 SL	K10104119159110	40	40	80	M20X2	115	2
SK 40 WE40 160 AD/6.3G15000 SL	K10104119175110	40	40	80	M20X2	160	2

Note: All Dimensions are in mm
 These Holders are most suitable for Weldon Type End Mill as per standard DIN 1835 - B

Maximum Run out of the Internal Dia with respect to the External Taper 0.005 mm

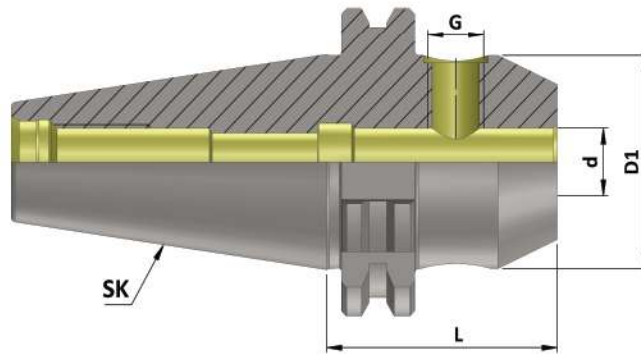

SK (DIN 69871)
 DIN ISO 7388 - 1
 Holders

SK (DIN 69871) (WE) (AD)

(Balanced to 6.3 G 15000 RPM)

Item Name	Item Code	SK	d	D1	G	L	Screw Qty.
SK 50 WE 06 063 AD/6.3G15000 SL	K10105111119110	50	6	25	M6	63	1
SK 50 WE 06 100 AD/6.3G15000 SL	K10105111148110	50	6	25	M6	100	1
SK 50 WE 06 160 AD/6.3G15000 SL	K10105111175110	50	6	25	M6	160	1
SK 50 WE 08 063 AD/6.3G15000 SL	K10105112119110	50	8	28	M8	63	1
SK 50 WE 08 100 AD/6.3G15000 SL	K10105112148110	50	8	28	M8	100	1
SK 50 WE 08 160 AD/6.3G15000 SL	K10105112175110	50	8	28	M8	160	1
SK 50 WE 10 063 AD/6.3G15000 SL	K10105113119110	50	10	35	M10	63	1
SK 50 WE 10 100 AD/6.3G15000 SL	K10105113148110	50	10	35	M10	100	1
SK 50 WE 10 160 AD/6.3G15000 SL	K10105113175110	50	10	35	M10	160	1
SK 50 WE 12 063 AD/6.3G15000 SL	K10105114119110	50	12	42	M12	63	1
SK 50 WE 12 100 AD/6.3G15000 SL	K10105114148110	50	12	42	M12	100	1
SK 50 WE 12 160 AD/6.3G15000 SL	K10105114175110	50	12	42	M12	160	1
SK 50 WE 14 063 AD/6.3G15000 SL	K10105258119110	50	14	44	M12	63	1
SK 50 WE 14 100 AD/6.3G15000 SL	K10105258148110	50	14	44	M12	100	1
SK 50 WE 14 160 AD/6.3G15000 SL	K10105258175110	50	14	44	M12	160	1
SK 50 WE 16 063 AD/6.3G15000 SL	K10105115119110	50	16	48	M14	63	1
SK 50 WE 16 100 AD/6.3G15000 SL	K10105115148110	50	16	48	M14	100	1
SK 50 WE 16 160 AD/6.3G15000 SL	K10105115175110	50	16	48	M14	160	1
SK 50 WE 18 063 AD/6.3G15000 SL	K10105259119110	50	18	50	M14	63	1
SK 50 WE 18 100 AD/6.3G15000 SL	K10105259148110	50	18	50	M14	100	1
SK 50 WE 18 160 AD/6.3G15000 SL	K10105259175110	50	18	50	M14	160	1
SK 50 WE 20 063 AD/6.3G15000 SL	K10105116119110	50	20	52	M16	63	1
SK 50 WE 20 100 AD/6.3G15000 SL	K10105116148110	50	20	52	M16	100	1
SK 50 WE 20 160 AD/6.3G15000 SL	K10105116175110	50	20	52	M16	160	1
SK 50 WE 25 080 AD/6.3G15000 SL	K10105117131110	50	25	65	M18X2	80	2
SK 50 WE 25 100 AD/6.3G15000 SL	K10105117148110	50	25	65	M18X2	100	2
SK 50 WE 25 160 AD/6.3G15000 SL	K10105117175110	50	25	65	M18X2	160	2
SK 50 WE 32 100 AD/6.3G15000 SL	K10105118148110	50	32	72	M20X2	100	2
SK 50 WE 32 160 AD/6.3G15000 SL	K10105118175110	50	32	72	M20X2	160	2
SK 50 WE 40 120 AD/6.3G15000 SL	K10105119162110	50	40	80	M20X2	120	2
SK 50 WE 40 160 AD/6.3G15000 SL	K10105119175110	50	40	80	M20X2	160	2
SK 50 WE 50 120 AD/6.3G15000 SL	K10105120162110	50	50	100	M24X2	120	2

Note: All Dimensions are in mm
 These Holders are most suitable for Weldon Type End Mill as per standard DIN 1835 - B

Maximum Run out of the Internal Dia with respect to the External Taper 0.005 mm

SK (DIN 69871)
DIN ISO 7388 - 1
Holders

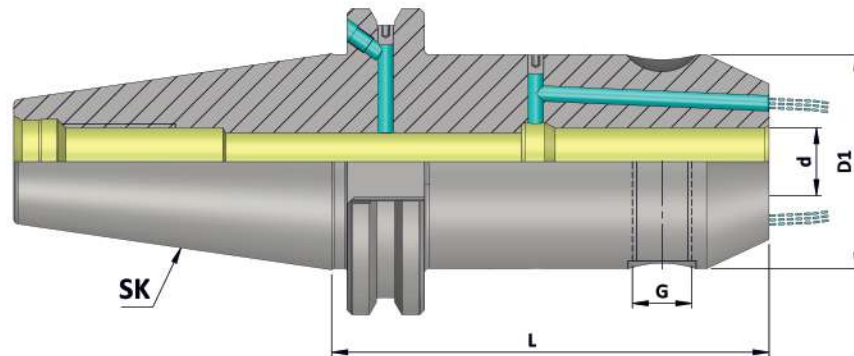

SK (WE) (FCC) (AD+B) AD/ AF

(Balanced to 2.5 G 25000 RPM)

Item Name	Item Code	SK	d	D1	G	L	Screw Qty.
SK40 WE06 050 FCC AD+B/2.5G 25000SL	K10104111111263	40	6	25	M6	50	1
SK40 WE06 100 FCC AD+B/2.5G 25000SL	K10104111148263	40	6	25	M6	100	1
SK40 WE06 160 FCC AD+B/2.5G 25000SL	K10104111175263	40	6	25	M6	160	1
SK40 WE08 050 FCC AD+B/2.5G 25000SL	K10104112111263	40	8	28	M8	50	1
SK40 WE08 100 FCC AD+B/2.5G 25000SL	K10104112148263	40	8	28	M8	100	1
SK40 WE08 160 FCC AD+B/2.5G 25000SL	K10104112175263	40	8	28	M8	160	1
SK40 WE10 050 FCC AD+B/2.5G 25000SL	K10104113111263	40	10	35	M10	50	1
SK40 WE10 100 FCC AD+B/2.5G 25000SL	K10104113148263	40	10	35	M10	100	1
SK40 WE10 160 FCC AD+B/2.5G 25000SL	K10104113175263	40	10	35	M10	160	1
SK40 WE12 050 FCC AD+B/2.5G 25000SL	K10104114111263	40	12	42	M12	50	1
SK40 WE12 100 FCC AD+B/2.5G 25000SL	K10104114148263	40	12	42	M12	100	1
SK40 WE12 160 FCC AD+B/2.5G 25000SL	K10104114175263	40	12	42	M12	160	1
SK40 WE14 050 FCC AD+B/2.5G 25000SL	K10104258111263	40	14	44	M12	50	1
SK40 WE14 100 FCC AD+B/2.5G 25000SL	K10104258148263	40	14	44	M12	100	1
SK40 WE14 160 FCC AD+B/2.5G 25000SL	K10104258175263	40	14	44	M12	160	1
SK40 WE16 063 FCC AD+B/2.5G 25000SL	K10104115563263	40	16	48	M14	63	1
SK40 WE16 100 FCC AD+B/2.5G 25000SL	K10104115148263	40	16	48	M14	100	1
SK40 WE16 160 FCC AD+B/2.5G 25000SL	K10104115175263	40	16	48	M14	160	1
SK40 WE18 063 FCC AD+B/2.5G 25000SL	K10104259563263	40	18	50	M14	63	1
SK40 WE18 100 FCC AD+B/2.5G 25000SL	K10104259148263	40	18	50	M14	100	1
SK40 WE18 160 FCC AD+B/2.5G 25000SL	K10104259175263	40	18	50	M14	160	1
SK40 WE20 063 FCC AD+B/2.5G 25000SL	K10104116563263	40	20	52	M16	63	1
SK40 WE20 100 FCC AD+B/2.5G 25000SL	K10104116148263	40	20	52	M16	100	1
SK40 WE20 160 FCC AD+B/2.5G 25000SL	K10104116175263	40	20	52	M16	160	1
SK40 WE25 100 FCC AD+B/2.5G 25000SL	K10104117148263	40	25	65	M18X2	100	2
SK40 WE25 160 FCC AD+B/2.5G 25000SL	K10104117175263	40	25	65	M18X2	160	2
SK40 WE32 100 FCC AD+B/2.5G 25000SL	K10104118148263	40	32	72	M20X2	100	2
SK40 WE32 160 FCC AD+B/2.5G 25000SL	K10104118175263	40	32	72	M20X2	160	2
SK40 WE40 115 FCC AD+B/2.5G 25000SL	K10104119159263	40	40	80	M20X2	115	2
SK40 WE40 160 FCC AD+B/2.5G 25000SL	K10104119175263	40	40	80	M20X2	160	2

Note: All Dimensions are in mm
These Holders are most suitable for Weldon Type End Mill as per standard DIN 1835 - B

Maximum Run out of the Internal Dia with respect to the External Taper 0.005 mm

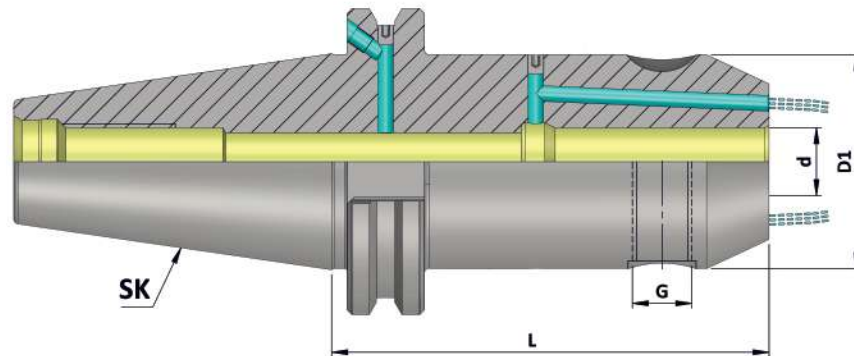

SK (DIN 69871)
DIN ISO 7388 - 1
Holders

SK (WE) (FCC) (AD+B) AD/ AF

(Balanced to 2.5 G 25000 RPM)

Item Name	Item Code	SK	d	D1	G	L	Screw Qty.
SK50 WE06 063 FCC AD+B/2.5G 25000SL	K10105111563263	50	6	25	M6	63	1
SK50 WE06 100 FCC AD+B/2.5G 25000SL	K10105111148263	50	6	25	M6	100	1
SK50 WE06 160 FCC AD+B/2.5G 25000SL	K10105111175263	50	6	25	M6	160	1
SK50 WE08 063 FCC AD+B/2.5G 25000SL	K10105112563263	50	8	28	M8	63	1
SK50 WE08 100 FCC AD+B/2.5G 25000SL	K10105112148263	50	8	28	M8	100	1
SK50 WE08 160 FCC AD+B/2.5G 25000SL	K10105112175263	50	8	28	M8	160	1
SK50 WE10 063 FCC AD+B/2.5G 25000SL	K10105113563263	50	10	35	M10	63	1
SK50 WE10 100 FCC AD+B/2.5G 25000SL	K10105113148263	50	10	35	M10	100	1
SK50 WE10 160 FCC AD+B/2.5G 25000SL	K10105113175263	50	10	35	M10	160	1
SK50 WE12 063 FCC AD+B/2.5G 25000SL	K10105114148263	50	12	42	M12	63	1
SK50 WE12 100 FCC AD+B/2.5G 25000SL	K10105114563263	50	12	42	M12	100	1
SK50 WE12 160 FCC AD+B/2.5G 25000SL	K10105114175263	50	12	42	M12	160	1
SK50 WE14 063 FCC AD+B/2.5G 25000SL	K10105258563263	50	14	44	M12	63	1
SK50 WE14 100 FCC AD+B/2.5G 25000SL	K10105258148263	50	14	44	M12	100	1
SK50 WE14 160 FCC AD+B/2.5G 25000SL	K10105258175263	50	14	44	M12	160	1
SK50 WE16 063 FCC AD+B/2.5G 25000SL	K10105115563263	50	16	48	M14	63	1
SK50 WE16 100 FCC AD+B/2.5G 25000SL	K10105115148263	50	16	48	M14	100	1
SK50 WE16 160 FCC AD+B/2.5G 25000SL	K10105115175263	50	16	48	M14	160	1
SK50 WE18 063 FCC AD+B/2.5G 25000SL	K10105259563263	50	18	50	M14	63	1
SK50 WE18 100 FCC AD+B/2.5G 25000SL	K10105259148263	50	18	50	M14	100	1
SK50 WE18 160 FCC AD+B/2.5G 25000SL	K10105259175263	50	18	50	M14	160	1
SK50 WE20 063 FCC AD+B/2.5G 25000SL	K10105116563263	50	20	52	M16	63	1
Sk50 WE20 100 FCC AD+B/2.5G 25000SL	K10105116148263	50	20	52	M16	100	1
SK50 WE20 160 FCC AD+B/2.5G 25000SL	K10105116175263	50	20	52	M16	160	1
SK50 WE25 080 FCC AD+B/2.5G 25000SL	K10105117131263	50	25	65	M18X2	80	2
SK50 WE25 100 FCC AD+B/2.5G 25000SL	K10105117148263	50	25	65	M18X2	100	2
SK50 WE25 160 FCC AD+B/2.5G 25000SL	K10105117175263	50	25	65	M18X2	160	2
SK50 WE32 100 FCC AD+B/2.5G 25000SL	K10105118148263	50	32	72	M20X2	100	2
SK50 WE32 160 FCC AD+B/2.5G 25000SL	K10105118175263	50	32	72	M20X2	160	2
SK50 WE40 120 FCC AD+B/2.5G 25000SL	K10105119162263	50	40	80	M20X2	120	2
SK50 WE40 160 FCC AD+B/2.5G 25000SL	K10105119175263	50	40	80	M20X2	160	2
SK50 WE50 120 FCC AD+B/2.5G 25000SL	K10105120162263	50	50	100	M24X2	120	2

Note: All Dimensions are in mm
These Holders are most suitable for Weldon Type End Mill as per standard DIN 1835 - B

Maximum Run out of the External Dia with respect to the External Taper 0.005 mm

SK (DIN 69871)
DIN ISO 7388 - 1
Holders

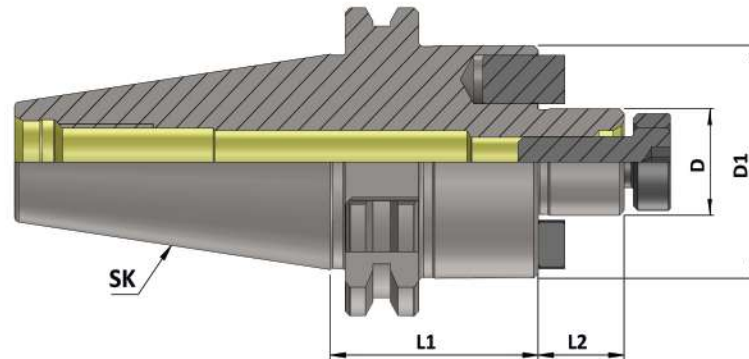

SK (DIN 69871) (FMH) (AD)

(Balanced to 6.3 G 15000 RPM)

Item Name	Item Code	SK	D	D1	L1	L2
SK 40 FMH16 045 AD/6.3G15000 SL SP.S	K10104126108232	40	16	38	45	17
SK 40 FMH16 100 AD/6.3G15000 SL SP.S	K10104126148232	40	16	38	100	17
SK 40 FMH16 160 AD/6.3G15000 SL SP.S	K10104126175232	40	16	38	160	17
SK 40 FMH22 045 AD/6.3G15000 SL SP.S	K10104127108232	40	22	48	45	19
SK 40 FMH22 100 AD/6.3G15000 SL SP.S	K10104127148232	40	22	48	100	19
SK 40 FMH22 160 AD/6.3G15000 SL SP.S	K10104127175232	40	22	48	160	19
SK 40 FMH27 050 AD/6.3G15000 SL SP.S	K10104128111232	40	27	58	50	21
SK 40 FMH27 100 AD/6.3G15000 SL SP.S	K10104128148232	40	27	58	100	21
SK 40 FMH27 160 AD/6.3G15000 SL SP.S	K10104128175232	40	27	58	160	21
SK 40 FMH32 055 AD/6.3G15000 SL SP.S	K10104129115232	40	32	78	55	24
SK 40 FMH32 100 AD/6.3G15000 SL SP.S	K10104129148232	40	32	78	100	24
SK 40 FMH32 160 AD/6.3G15000 SL SP.S	K10104129175232	40	32	78	160	24
SK 40 FMH40 055 AD/6.3G15000 SL SP.S	K10104130115232	40	40	88	55	27
SK 40 FMH40 100 AD/6.3G15000 SL SP.S	K10104130148232	40	40	88	100	27
SK 40 FMH40 160 AD/6.3G15000 SL SP.S	K10104130175232	40	40	88	160	27

SK 50 FMH16 045 AD/6.3G15000 SL SP.S	K10105126108232	50	16	38	45	17
SK 50 FMH16 100 AD/6.3G15000 SL SP.S	K10105126148232	50	16	38	100	17
SK 50 FMH16 160 AD/6.3G15000 SL SP.S	K10105126175232	50	16	38	160	17
SK 50 FMH22 045 AD/6.3G15000 SL SP.S	K10105127108232	50	22	48	45	19
SK 50 FMH22 100 AD/6.3G15000 SL SP.S	K10105127148232	50	22	48	100	19
SK 50 FMH22 160 AD/6.3G15000 SL SP.S	K10105127175232	50	22	48	160	19
SK 50 FMH27 045 AD/6.3G15000 SL SP.S	K10105128108232	50	27	58	45	21
SK 50 FMH27 100 AD/6.3G15000 SL SP.S	K10105128148232	50	27	58	100	21
SK 50 FMH27 160 AD/6.3G15000 SL SP.S	K10105128175232	50	27	58	160	21
SK 50 FMH32 050 AD/6.3G15000 SL SP.S	K10105129111232	50	32	78	50	24
SK 50 FMH32 100 AD/6.3G15000 SL SP.S	K10105129148232	50	32	78	100	24
SK 50 FMH32 160 AD/6.3G15000 SL SP.S	K10105129175232	50	32	78	160	24
SK 50 FMH40 055 AD/6.3G15000 SL SP.S	K10105267115232	50	40	88	55	27
SK 50 FMH40 100 AD/6.3G15000 SL SP.S	K10105267148232	50	40	88	100	27
SK 50 FMH40 160 AD/6.3G15000 SL SP.S	K10105267175232	50	40	88	160	27

Note: All Dimensions are in mm

Maximum Run out of the External Dia with respect to the External Taper 0.005 mm

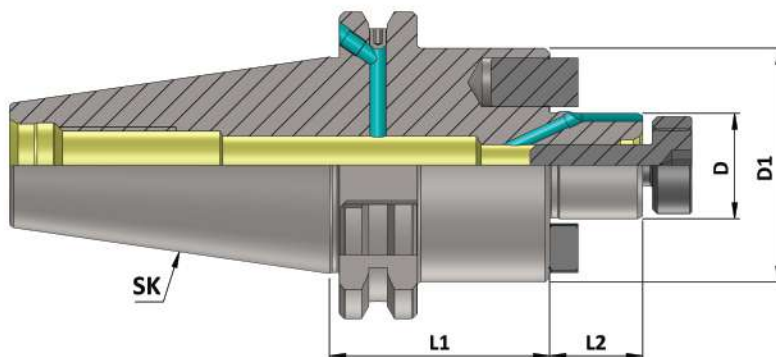

SK (DIN 69871)
DIN ISO 7388 - 1
Holders

SK (DIN 69871) (FMH-K) (AD+B) AD/AF

(Balanced to 6.3 G 15000 RPM)

Item Name	Item Code	SK	D	D1	L1	L2
SK 40 FMH-K16 045 AD+B/6.3G15000 SL SP.S	K10104131108234	40	16	38	45	17
SK 40 FMH-K16 100 AD+B/6.3G15000 SL SP.S	K10104131148234	40	16	38	100	17
SK 40 FMH-K16 160 AD+B/6.3G15000 SL SP.S	K10104131175234	40	16	38	160	17
SK 40 FMH-K22 045 AD+B/6.3G15000 SL SP.S	K10104132108234	40	22	48	45	19
SK 40 FMH-K22 100 AD+B/6.3G15000 SL SP.S	K10104132148234	40	22	48	100	19
SK 40 FMH-K22 160 AD+B/6.3G15000 SL SP.S	K10104132175234	40	22	48	160	19
SK 40 FMH-K27 050 AD+B/6.3G15000 SL SP.S	K10104133111234	40	27	58	50	21
SK 40 FMH-K27 100 AD+B/6.3G15000 SL SP.S	K10104133148234	40	27	58	100	21
SK 40 FMH-K27 160 AD+B/6.3G15000 SL SP.S	K10104133175234	40	27	58	160	21
SK 40 FMH-K32 055 AD+B/6.3G15000 SL SP.S	K10104134115234	40	32	78	55	24
SK 40 FMH-K32 100 AD+B/6.3G15000 SL SP.S	K10104134148234	40	32	78	100	24
SK 40 FMH-K32 160 AD+B/6.3G15000 SL SP.S	K10104134175234	40	32	78	160	24
SK 40 FMH-K40 055 AD+B/6.3G15000 SL SP.S	K10104135115234	40	40	88	55	27
SK 40 FMH-K40 100 AD+B/6.3G15000 SL SP.S	K10104135148234	40	40	88	100	27
SK 40 FMH-K40 160 AD+B/6.3G15000 SL SP.S	K10104135175234	40	40	88	160	27

SK 50 FMH-K16 045 AD+B/6.3G15000 SL SP.S	K10105131108234	50	16	38	45	17
SK 50 FMH-K16 100 AD+B/6.3G15000 SL SP.S	K10105131148234	50	16	38	100	17
SK 50 FMH-K16 160 AD+B/6.3G15000 SL SP.S	K10105131175234	50	16	38	160	17
SK 50 FMH-K22 045 AD+B/6.3G15000 SL SP.S	K10105132108234	50	22	48	45	19
SK 50 FMH-K22 100 AD+B/6.3G15000 SL SP.S	K10105132148234	50	22	48	100	19
SK 50 FMH-K22 160 AD+B/6.3G15000 SL SP.S	K10105132175234	50	22	48	160	19
SK 50 FMH-K27 045 AD+B/6.3G15000 SL SP.S	K10105133108234	50	27	58	45	21
SK 50 FMH-K27 100 AD+B/6.3G15000 SL SP.S	K10105133148234	50	27	58	100	21
SK 50 FMH-K27 160 AD+B/6.3G15000 SL SP.S	K10105133175234	50	27	58	160	21
SK 50 FMH-K32 050 AD+B/6.3G15000 SL SP.S	K10105134111234	50	32	78	50	24
SK 50 FMH-K32 100 AD+B/6.3G15000 SL SP.S	K10105134148234	50	32	78	100	24
SK 50 FMH-K32 160 AD+B/6.3G15000 SL SP.S	K10105134175234	50	32	78	160	24
SK 50 FMH-K40 055 AD+B/6.3G15000 SL SP.S	K10105135115234	50	40	88	55	27
SK 50 FMH-K40 100 AD+B/6.3G15000 SL SP.S	K10105135148234	50	40	88	100	27
SK 50 FMH-K40 160 AD+B/6.3G15000 SL SP.S	K10105576175234	50	40	88	160	27

Note: All Dimensions are in mm

Maximum Run out of the External Dia with respect to the External Taper 0.005 mm

SK (DIN 69871)
DIN ISO 7388 - 1
Holders

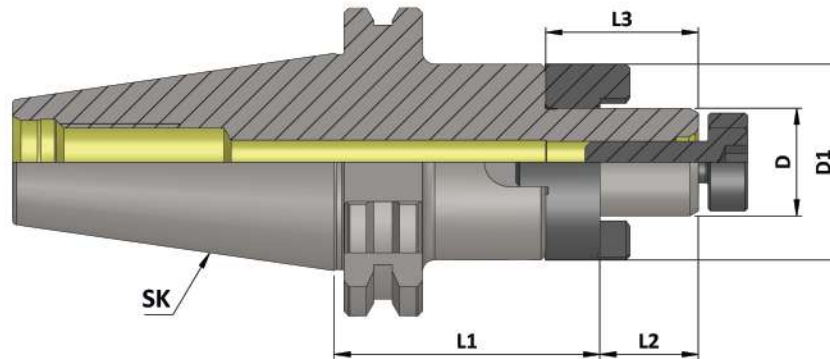

SK (DIN 69871) (CSMA)

(Balanced to 6.3 G 15000 RPM)

Item Name	Item Code	SK	D	D1	L1	L2	L3
SK 40 CSMA16 055 AD/6.3G15000 SL S.P.S	K10104121115232	40	16	32	55	17	27
SK 40 CSMA16 100 AD/6.3G15000 SL S.P.S	K10104121148232	40	16	32	100	17	27
SK 40 CSMA16 160 AD/6.3G15000 SL S.P.S	K10104121175232	40	16	32	160	17	27
SK 40 CSMA22 055 AD/6.3G15000 SL S.P.S	K10104122115232	40	22	40	55	19	31
SK 40 CSMA22 100 AD/6.3G15000 SL S.P.S	K10104122148232	40	22	40	100	19	31
SK 40 CSMA22 160 AD/6.3G15000 SL S.P.S	K10104122175232	40	22	40	160	19	31
SK 40 CSMA27 055 AD/6.3G15000 SL S.P.S	K10104123115232	40	27	48	55	21	33
SK 40 CSMA27 100 AD/6.3G15000 SL S.P.S	K10104123148232	40	27	48	100	21	33
SK 40 CSMA27 160 AD/6.3G15000 SL S.P.S	K10104123175232	40	27	48	160	21	33
SK 40 CSMA32 060 AD/6.3G15000 SL S.P.S	K10104124117232	40	32	58	60	24	38
SK 40 CSMA32 100 AD/6.3G15000 SL S.P.S	K10104124148232	40	32	58	100	24	38
SK 40 CSMA32 160 AD/6.3G15000 SL S.P.S	K10104124175232	40	32	58	160	24	38
SK 40 CSMA40 060 AD/6.3G15000 SL S.P.S	K10104125117232	40	40	70	60	27	41
SK 40 CSMA40 100 AD/6.3G15000 SL S.P.S	K10104125148232	40	40	70	100	27	41
SK 40 CSMA40 160 AD/6.3G15000 SL S.P.S	K10104125175232	40	40	70	160	27	41

SK 50 CSMA16 055 AD/6.3G15000 SL S.P.S	K10105121115232	50	16	32	55	17	27
SK 50 CSMA16 100 AD/6.3G15000 SL S.P.S	K10105121148232	50	16	32	100	17	27
SK 50 CSMA16 160 AD/6.3G15000 SL S.P.S	K10105121175232	50	16	32	160	17	27
SK 50 CSMA22 055 AD/6.3G15000 SL S.P.S	K10105122115232	50	22	40	55	19	31
SK 50 CSMA22 100 AD/6.3G15000 SL S.P.S	K10105122148232	50	22	40	100	19	31
SK 50 CSMA22 160 AD/6.3G15000 SL S.P.S	K10105122175232	50	22	40	160	19	31
SK 50 CSMA27 055 AD/6.3G15000 SL S.P.S	K10105123115232	50	27	48	55	21	33
SK 50 CSMA27 100 AD/6.3G15000 SL S.P.S	K10105123148232	50	27	48	100	21	33
SK 50 CSMA27 160 AD/6.3G15000 SL S.P.S	K10105123175232	50	27	48	160	21	33
SK 50 CSMA32 055 AD/6.3G15000 SL S.P.S	K10105124115232	50	32	58	55	24	38
SK 50 CSMA32 100 AD/6.3G15000 SL S.P.S	K10105124148232	50	32	58	100	24	38
SK 50 CSMA32 160 AD/6.3G15000 SL S.P.S	K10105124175232	50	32	58	160	24	38
SK 50 CSMA40 055 AD/6.3G15000 SL S.P.S	K10105125115232	50	40	70	55	27	41
SK 50 CSMA40 100 AD/6.3G15000 SL S.P.S	K10105125148232	50	40	70	100	27	41
SK 50 CSMA40 160 AD/6.3G15000 SL S.P.S	K10105125175232	50	40	70	160	27	41

Note: All Dimensions are in mm

Maximum Run out of the Internal Taper with respect to the External Taper 0.005 mm

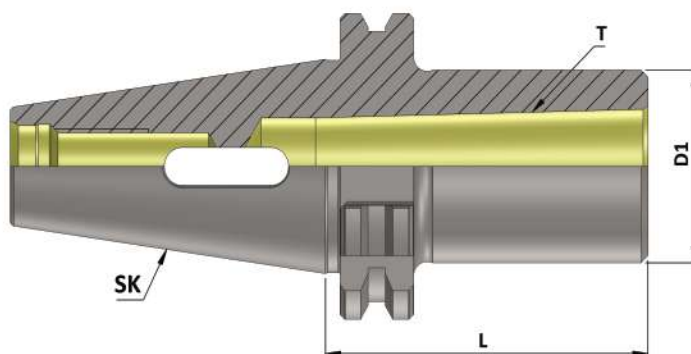

SK (DIN 69871)
 DIN ISO 7388 - 1
 Holders

SK (DIN 69871) (MTA)

(Balanced to 6.3 G 15000 RPM)

Item Name	Item Code	SK	Morse Taper (T)	D1	L
SK 40 MT01 050 6.3G15000 SL	K10104447111122	40	1	25	50
SK 40 MT01 115 6.3G15000 SL	K10104447159122	40	1	25	115
SK 40 MT02 050 6.3G15000 SL	K10104448111122	40	2	32	50
SK 40 MT02 125 6.3G15000 SL	K10104448164122	40	2	32	125
SK 40 MT03 070 6.3G15000 SL	K10104449125122	40	3	40	70
SK 40 MT03 140 6.3G15000 SL	K10104449169122	40	3	40	140
SK 40 MT04 095 6.3G15000 SL	K10104451145122	40	4	48	95

SK 50 MT01 050 6.3G15000 SL	K10105447111110	50	1	25	50
SK 50 MT01 120 6.3G15000 SL	K10105447162110	50	1	25	120
SK 50 MT02 060 6.3G15000 SL	K10105448117110	50	2	32	60
SK 50 MT02 140 6.3G15000 SL	K10105448169110	50	2	32	140
SK 50 MT03 065 6.3G15000 SL	K10105449123110	50	3	40	65
SK 50 MT03 150 6.3G15000 SL	K10105449173110	50	3	40	150
SK 50 MT04 095 6.3G15000 SL	K10105451145110	50	4	48	95
SK 50 MT04 180 6.3G15000 SL	K10105451178110	50	4	48	180
SK 50 MT05 120 6.3G15000 SL	K10105450162110	50	5	63	120
SK 50 MT05 220 6.3G15000 SL	K10105450180110	50	5	63	220

Note: All Dimensions are in mm

Maximum Run out of the Internal Taper with respect to the External Taper 0.005 mm

SK (DIN 69871)
DIN ISO 7388 - 1
Holders

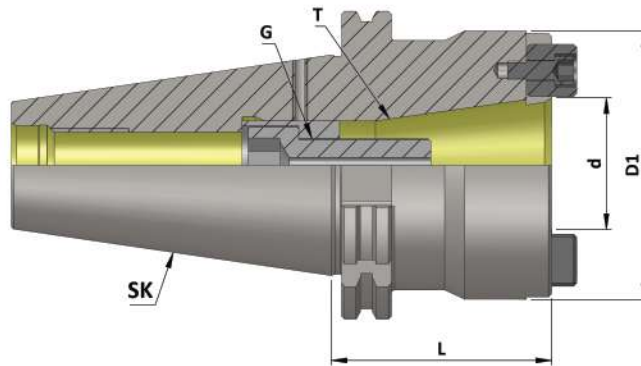

SK (DIN 69871) Reduction Sleeve

Item Name	Item Code	SK	d	D1	T	L	G
SK 50 X SK40 REDUCTION SLEEVE	K10105347486127	50	44.45	85	7:24	70	M 16

Note: All Dimensions are in mm

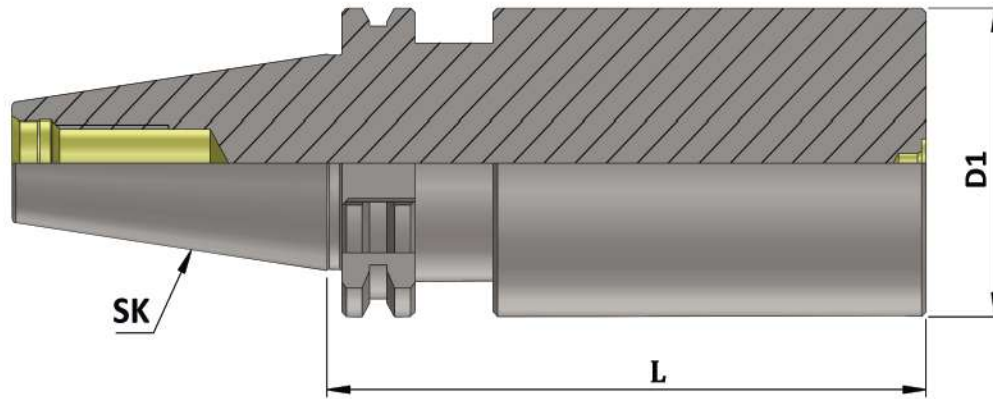

SK (DIN 69871)
DIN ISO 7388 - 1
Holders

SK (DIN 69871) Boring Bar Blank

Item Name	Item Code	SK	D1	L
SK 40 BORING BAR BLANK DIA 63.5 L 160	K10104173330127	40	63.5	160
SK 40 BORING BAR BLANK DIA 63.5 L 250	K10104173256127	40	63.5	250
SK 50 BORING BAR BLANK DIA 80.0 L 160	K10105264330127	50	80	160
SK 50 BORING BAR BLANK DIA 80.0 L 200	K10105264237127	50	80	200
SK 50 BORING BAR BLANK DIA 80.0 L 250	K10105264256127	50	80	250
SK 50 BORING BAR BLANK DIA 80.0 L 300	K10105264257127	50	80	300
SK 50 BORING BAR BLANK DIA 97.0 L 315	K10105265329127	50	97	315

Note: All Dimensions are in mm

Maximum Run out of the External Dia with respect to the External Taper 0.003 mm

SK (DIN 69871)
DIN ISO 7388 - 1
Holders

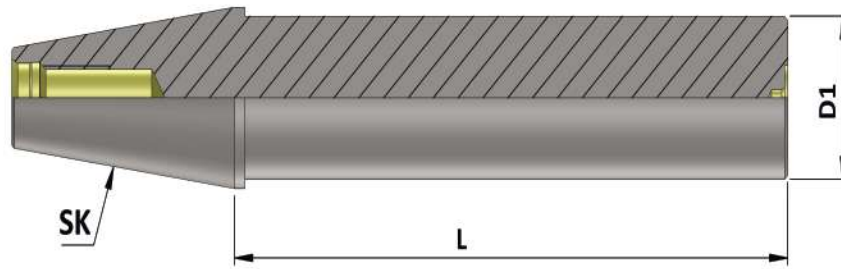

SK (DIN 69871) Master Mandrell

(Sub Zero Treated)

Item Name	Item Code	SK	D1	L
SK 40 MASTER MANDREL DIA40 L 300	K10104165257127	40	40	300
SK 50 MASTER MANDREL DIA50 L 350	K10105166258127	50	50	350

Note: All Dimensions are in mm

Maximum Run out on the Mandrell with respect to the External Taper 0.050 mm

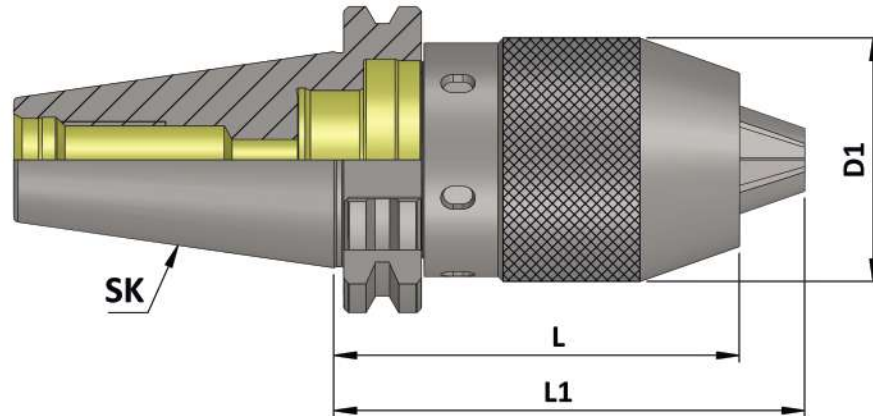

SK (DIN 69871)
DIN ISO 7388 - 1
Holders

SK (DIN 69871) (NCDC)

Item Name	Item Code	SK	D1	L	L1
SK 40 NCDC 1-13 86	K10104167157110	40	50	86	98.5
SK 50 NCDC 1-13 108	K10105167151110	50	50	108	120.5

Accessories:



NCDC Spanner
Ref. Page No. 223

Note: All Dimensions are in mm

◆ Features:

- Small outside diameter.
- Best suitable for Die & Mould Industry.
- Most suitable for machining of cavities difficult to reach.
- High precision Runout < 0.005mm (4xd).
- All 'KTA' Die & Mould Chucks are subjected to Sub-zero treatment (-90° C). This treatment helps to prevent the holders from deformation for many years & hence increases the life.

◆ Capacity:

- DMC 06 (3mm to 6mm)
- DMC 08 (3mm to 8mm)
- DMC 10 (3mm to 10mm)

◆ Available In Mountings :

- BT (MAS 403) (DIN ISO 7388 - 2)
- BBT (MAS 403)
- SK (DIN 69871) (DIN ISO 7388 - 1)
- HSK- A (DIN 69893-1)
- Cylindrical Shank

◆ Balancing :

- Balanced To 2.5 G 25000 RPM



Maximum Run out of the Internal Taper with respect to the External Taper < 0.005 mm

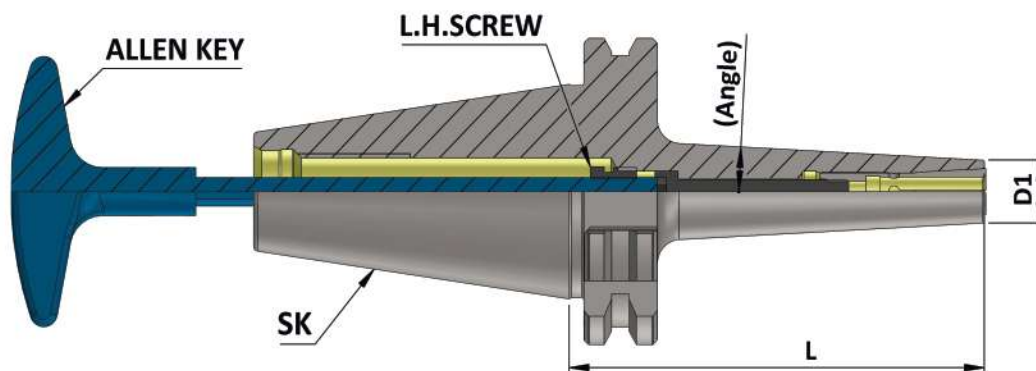

SK (DIN 69871)
DIN ISO 7388 - 1
Holders

SK (DIN 69871) (DMC)

(Balanced to 2.5 G 25000 RPM)

Item Name	Item Code	SK	Gripping Range	D1	L	Angle	Suitable Collet	Locking Screw	Allen Key
SK 40 DMC 06 060 AD/2.5G 25000 SL	K10104161117129	40	3-6	13	60	3	DMC-6	M5	4X200
SK 40 DMC 06 090 AD/2.5G 25000 SL	K10104161140129	40	3-6	13	90	3	DMC-6	M5	4X200
SK 40 DMC 06 120 AD/2.5G 25000 SL	K10104161162129	40	3-6	13	120	3	DMC-6	M5	4X200
SK 40 DMC 06 160 AD/ 2.5G 25000 SL	K10104161175124	40	3-6	13	160	3	DMC-6	M5	4X200
SK 40 DMC 08 090 AD/2.5G 25000 SL	K10104162140129	40	3-8	22	90	3	DMC-8	M6	5X200
SK 40 DMC 08 120 AD/2.5G 25000 SL	K10104162162129	40	3-8	22	120	3	DMC-8	M6	5X200
SK 40 DMC 08 160 AD/2.5G 25000 SL	K10104162175124	40	3-8	22	160	3	DMC-8	M6	5X200
SK 40 DMC 10 090 AD/2.5G 25000 SL	K10104163140129	40	3-10	28	90	-	DMC-10	M8	6X200
SK 40 DMC 10 120 AD/2.5G 25000 SL	K10104163162129	40	3-10	28	120	-	DMC-10	M8	6X200
SK 50 DMC 10 150 AD/2.5G 25000 SL	K10105163173129	50	3-10	28	150	-	DMC-10	M8	6X200

Accessories:



DMC Collet
Ref. Page No. 241

Note: All Dimensions are in mm



Power Milling Chuck (PMC)

◆ Features:

- 'KTA' Power Milling Chuck is Very Rigid & Precision.
- It is best for Drilling, Reaming & Milling Operations.
- The tool runs true less than 5 micron on 2D. Hence the tool life increases drastically.
- It's Unibody construction reduces the vibrations, This also helps to increase the tool life.
- All 'KTA' Power Milling Chucks are subjected to sub-zero treatment (-90° C). This treatment helps to prevent the holders from deformation for many years & hence increases the life.

◆ Available In Mountings :

- BT (MAS 403) (DIN ISO 7388 - 2)
- BBT (MAS 403)
- SK (DIN 69871) (DIN ISO 7388 - 1)
- HSK-A (DIN 69893-1)

◆ Balancing :

- Balanced To 6.3 G 15000 RPM



Maximum Run out of the Internal Dia with respect to the External Taper 0.005 mm

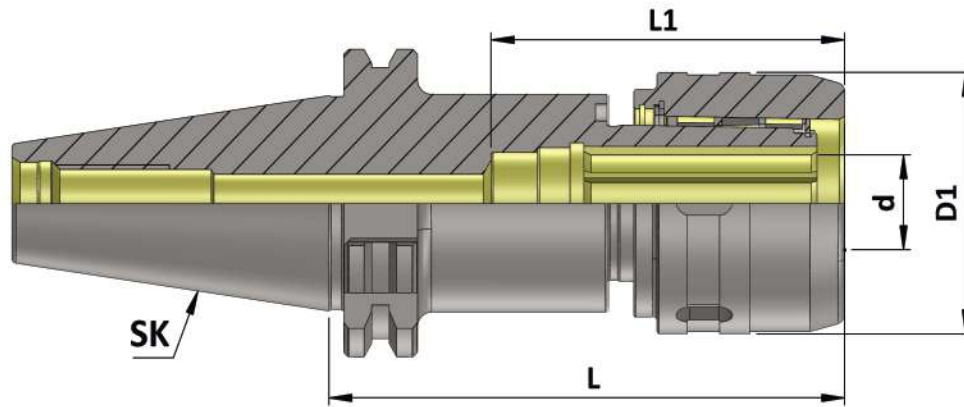

SK (DIN 69871)
DIN ISO 7388 - 1
Holders

SK (DIN 69871) (PMC)

(Balanced to 6.3 G 15000 RPM)

Item Name	Item Code	SK	d	D1	L	L1
SK 40 C 20105 AD/6.3 G15000 SL	K10104453355129	40	20	54	105	70
SK 40 C 32105 AD/6.3 G15000 SL	K10104453356129	40	32	72	105	100
SK 50 C 20105 AD/6.3 G15000 SL	K10105453355129	50	20	54	105	70
SK 50 C 32105 AD/6.3 G15000 SL	K10105453356129	50	32	72	105	100

Accessories:



Reduction Sleeve (RS)
Ref. Page No. 242



PMC Spanner
Ref. Page No. 223

Note: All Dimensions are in mm



Milling Cutter Arbor (MCA)

◆ Features:

- For Mounting of Screw type Modular Milling Cutters.
- Slim Design & hence easy to reach at deep cavities.
- Unibody Construction
- All 'KTA' Milling Cutter Arbors are subjected to Sub-zero treatment (-90° C). This treatment helps to prevent the holders from deformation for many years & hence increases the life.

◆ Available In Mountings :

- BT (MAS 403) (DIN ISO 7388 - 2)
- BBT (MAS 403)
- SK (DIN 69871) (DIN ISO 7388 - 1)
- HSK-A (DIN 69893-1)
- HSK-F (DIN 69893-6)

◆ Balancing :

- Balanced To 2.5 G 25000 RPM



Maximum Run out of the Internal Dia with respect to the External Taper 0.005 mm

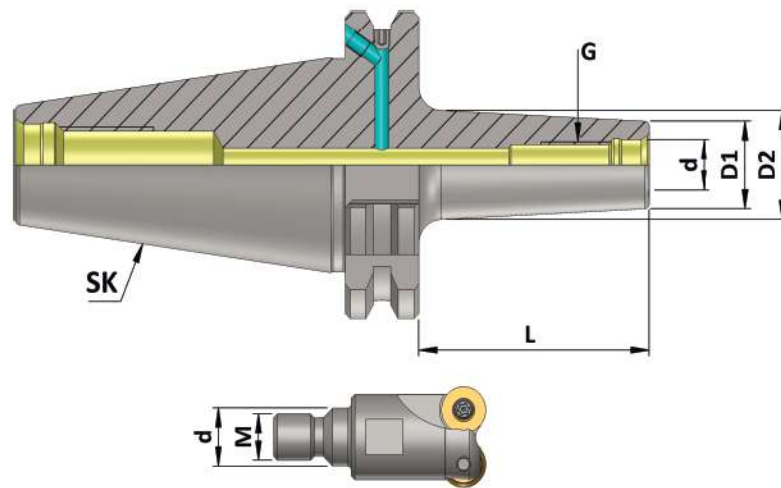

**SCREW-TYPE
 MODULAR MILLING CUTTER**

SK (DIN 69871)
 DIN ISO 7388 - 1
 Holders

SK (DIN 69871) (MCA)

(Balanced to 2.5 G 25000 RPM)

Item Name	Item Code	SK	d	D1	D2	G	L
SK 40 MCA06 025 AD+B/2.5G 25000 SL	K10104137101230	40	6.5	10	13	M6	25
SK 40 MCA06 050 AD+B/2.5G 25000 SL	K10104137111230	40	6.5	10	20	M6	50
SK 40 MCA06 075 AD+B/2.5G 25000 SL	K10104137127230	40	6.5	10	23	M6	75
SK 40 MCA08 025 AD+B/2.5G 25000 SL	K10104138101230	40	8.5	13	15	M8	25
SK 40 MCA08 050 AD+B/2.5G 25000 SL	K10104138111230	40	8.5	13	23	M8	50
SK 40 MCA08 075 AD+B/2.5G 25000 SL	K10104138127230	40	8.5	13	23	M8	75
SK 40 MCA08 100 AD+B/2.5G 25000 SL	K10104138148230	40	8.5	13	25	M8	100
SK 40 MCA10 025 AD+B/2.5G 25000 SL	K10104139101230	40	10.5	18	20	M10	25
SK 40 MCA10 050 AD+B/2.5G 25000 SL	K10104139111230	40	10.5	18	23	M10	50
SK 40 MCA10 075 AD+B/2.5G 25000 SL	K10104139127230	40	10.5	18	28	M10	75
SK 40 MCA10 100 AD+B/2.5G 25000 SL	K10104139148230	40	10.5	18	32	M10	100
SK 40 MCA12 025 AD+B/2.5G 25000 SL	K10104140101230	40	12.5	21	24	M12	25
SK 40 MCA12 050 AD+B/2.5G 25000 SL	K10104140111230	40	12.5	21	24	M12	50
SK 40 MCA12 075 AD+B/2.5G 25000 SL	K10104140127230	40	12.5	21	31	M12	75
SK 40 MCA12 100 AD+B/2.5G 25000 SL	K10104140148230	40	12.5	21	33	M12	100
SK 40 MCA12 125 AD+B/2.5G 25000 SL	K10104140164230	40	12.5	21	36	M12	125
SK 40 MCA16 025 AD+B/2.5G 25000 SL	K10104141101230	40	17	29	29	M16	25
SK 40 MCA16 050 AD+B/2.5G 25000 SL	K10104141111230	40	17	29	34	M16	50
SK 40 MCA16 075 AD+B/2.5G 25000 SL	K10104141127230	40	17	29	34	M16	75
SK 40 MCA16 100 AD+B/2.5G 25000 SL	K10104141148230	40	17	29	36	M16	100
SK 40 MCA16 125 AD+B/2.5G 25000 SL	K10104141164230	40	17	29	40	M16	125
SK 40 MCA16 150 AD+B/2.5G 25000 SL	K10104141173230	40	17	29	42.5	M16	150

Note: All Dimensions are in mm

Maximum Run out of the Internal Dia with respect to the External Taper 0.005 mm

SK (DIN 69871)
 DIN ISO 7388 - 1
 Holders

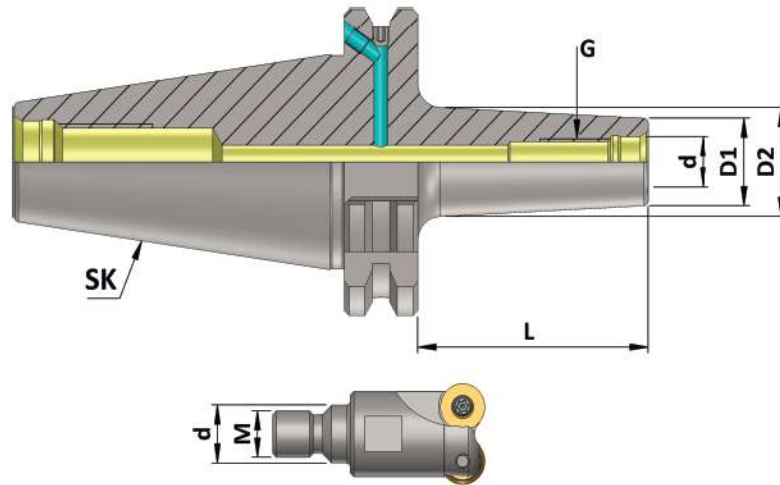

**SCREW-TYPE
 MODULAR MILLING CUTTER**

SK (DIN 69871) (MCA)

(Balanced to 2.5 G 25000 RPM)

Item Name	Item Code	SK	d	D1	D2	G	L
SK 50 MCA08 050 AD+B/2.5G 25000 SL	K10105138111230	50	8.5	13	23	M8	50
SK 50 MCA08 100 AD+B/2.5G 25000 SL	K10105138148230	50	8.5	13	25	M8	100
SK 50 MCA08 150 AD+B/2.5G 25000 SL	K10105138173230	50	8.5	13	30	M8	150
SK 50 MCA10 050 AD+B/2.5G 25000 SL	K10105139111230	50	10.5	18	23	M10	50
SK 50 MCA10 100 AD+B/2.5G 25000 SL	K10105139148230	50	10.5	18	32	M10	100
SK 50 MCA10 150 AD+B/2.5G 25000 SL	K10105139173230	50	10.5	18	36.5	M10	150
SK 50 MCA12 050 AD+B/2.5G 25000 SL	K10105140111230	50	12.5	21	24	M12	50
SK 50 MCA12 100 AD+B/2.5G 25000 SL	K10105140148230	50	12.5	21	33	M12	100
SK 50 MCA12 150 AD+B/2.5G 25000 SL	K10105140173230	50	12.5	21	40	M12	150
SK 50 MCA16 050 AD+B/2.5G 25000 SL	K10105141111230	50	17	29	34	M16	50
SK 50 MCA16 100 AD+B/2.5G 25000 SL	K10105141148230	50	17	29	36	M16	100
SK 50 MCA16 150 AD+B/2.5G 25000 SL	K10105141173230	50	17	29	42.5	M16	150

Note: All Dimensions are in mm



Shrink Fit Holder 4.5 Degree (SFH 4.5°)

◆ Features:

- For Mounting Of Carbide Drills, End Mills etc.
- Easy to Reach at Deep Cavities.
- Best T. I. R. & Rigidity during long working life, Result of in house Reasearch & Development & special Heat Treatment.

◆ Available In Mountings :

- BT (MAS 403) (DIN ISO 7388 - 2)
- BBT (MAS 403)
- SK (DIN 69871) (DIN ISO 7388 - 1)
- HSK-A (DIN 69893-1)
- HSK-F (DIN 69893-6)

◆ Balancing :

- Balanced To 2.5 G 25000 RPM



Maximum Run out of the Internal Dia with respect to the External Taper 0.003 mm

SK (DIN 69871)
DIN ISO 7388 - 1
Holders

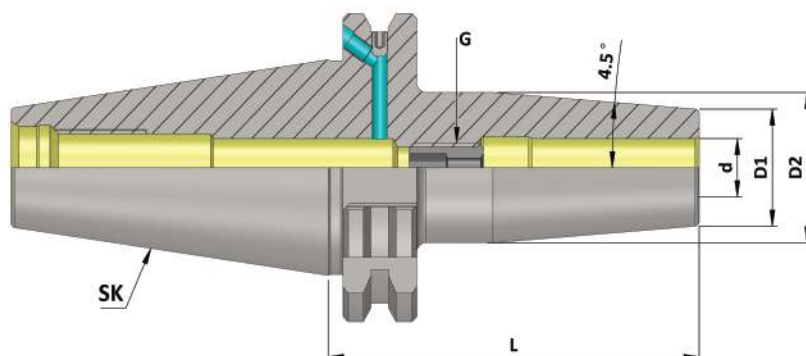

SK (DIN 69871) (SFH 4.5°) (AD+B) AD/AF

(Balanced to 2.5 G 25000 RPM)

Item Name	Item Code	SK	d	D1	D2	G	L
SK 40 SFH03 080 AD+B/2.5G 25000 SL	K10104274131140	40	3	10	20	-	80
SK 40 SFH03 120 AD+B/2.5G 25000 SL	K10104274162140	40	3	10	20	-	120
SK 40 SFH03 160 AD+B/2.5G 25000 SL	K10104274175140	40	3	10	20	-	160
SK 40 SFH04 080 AD+B/2.5G 25000 SL	K10104275131140	40	4	15	22	-	80
SK 40 SFH04 120 AD+B/2.5G 25000 SL	K10104275162140	40	4	15	22	-	120
SK 40 SFH04 160 AD+B/2.5G 25000 SL	K10104275175140	40	4	15	22	-	160
SK 40 SFH05 080 AD+B/2.5G 25000 SL	K10104276131140	40	5	15	22	-	80
SK 40 SFH05 120 AD+B/2.5G 25000 SL	K10104276162140	40	5	15	22	-	120
SK 40 SFH05 160 AD+B/2.5G 25000 SL	K10104276175140	40	5	15	22	-	160
SK 40 SFH06 080 AD+B/2.5G 25000 SL	K10104277131140	40	6	21	27	M5	80
SK 40 SFH06 120 AD+B/2.5G 25000 SL	K10104277162140	40	6	21	27	M5	120
SK 40 SFH06 160 AD+B/2.5G 25000 SL	K10104277175140	40	6	21	27	M5	160
SK 40 SFH08 080 AD+B/2.5G 25000 SL	K10104285131140	40	8	21	27	M6	80
SK 40 SFH08 120 AD+B/2.5G 25000 SL	K10104285162140	40	8	21	27	M6	120
SK 40 SFH08 160 AD+B/2.5G 25000 SL	K10104285175140	40	8	21	27	M6	160
SK 40 SFH10 080 AD+B/2.5G 25000 SL	K10104279131140	40	10	24	31	M8	80
SK 40 SFH10 120 AD+B/2.5G 25000 SL	K10104279162140	40	10	24	31	M8	120
SK 40 SFH10 160 AD+B/2.5G 25000 SL	K10104279175140	40	10	24	31	M8	160
SK 40 SFH12 080 AD+B/2.5G 25000 SL	K10104280131140	40	12	24	31	M10	80
SK 40 SFH12 120 AD+B/2.5G 25000 SL	K10104280162140	40	12	24	31	M10	120
SK 40 SFH12 160 AD+B/2.5G 25000 SL	K10104280175140	40	12	24	31	M10	160
SK 40 SFH14 080 AD+B/2.5G 25000 SL	K10104284131140	40	14	27	34	M10	80
SK 40 SFH14 120 AD+B/2.5G 25000 SL	K10104284162140	40	14	27	34	M10	120
SK 40 SFH14 160 AD+B/2.5G 25000 SL	K10104284175140	40	14	27	34	M10	160
SK 40 SFH16 080 AD+B/2.5G 25000 SL	K10104281131140	40	16	27	34	M12	80
SK 40 SFH16 120 AD+B/2.5G 25000 SL	K10104281162140	40	16	27	34	M12	120
SK 40 SFH16 160 AD+B/2.5G 25000 SL	K10104281175140	40	16	27	34	M12	160
SK 40 SFH18 080 AD+B/2.5G 25000 SL	K10104282131140	40	18	33	40	M12	80
SK 40 SFH18 120 AD+B/2.5G 25000 SL	K10104282162140	40	18	33	40	M12	120
SK 40 SFH18 160 AD+B/2.5G 25000 SL	K10104282175140	40	18	33	40	M12	160

Note: All Dimensions are in mm

Maximum Run out of the Internal Dia with respect to the External Taper 0.003 mm

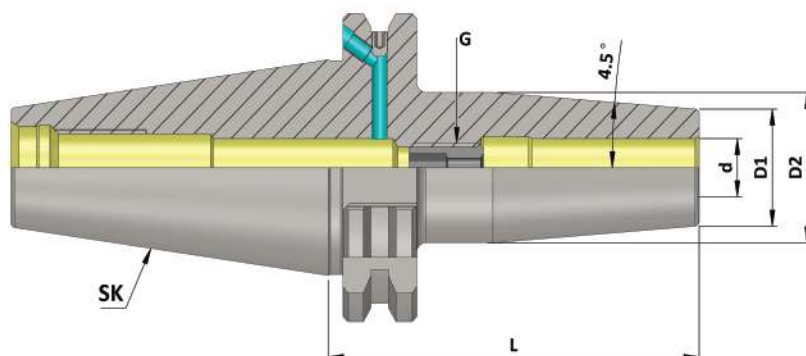

SK (DIN 69871)
DIN ISO 7388 - 1
Holders

SK (DIN 69871) (SFH 4.5°) (AD+B) AD/AF

(Balanced to 2.5 G 25000 RPM)

Item Name	Item Code	SK	d	D1	D2	G	L
SK 40 SFH20 080 AD+B/2.5G 25000 SL	K10104283131140	40	20	33	40	M16	80
SK 40 SFH20 120 AD+B/2.5G 25000 SL	K10104283162140	40	20	33	40	M16	120
SK 40 SFH20 160 AD+B/2.5G 25000 SL	K10104283175140	40	20	33	40	M16	160
SK 40 SFH25 100 AD+B/2.5G 25000 SL	K10104287148140	40	25	44	53	M16	100
SK 40 SFH25 120 AD+B/2.5G 25000 SL	K10104287162140	40	25	44	53	M16	120
SK 40 SFH25 160 AD+B/2.5G 25000 SL	K10104287175140	40	25	44	53	M16	160
SK 40 SFH32 100 AD+B/2.5G 25000 SL	K10104288148140	40	32	44	53	M16	100
SK 40 SFH32 120 AD+B/2.5G 25000 SL	K10104288162140	40	32	44	53	M16	120
SK 40 SFH32 160 AD+B/2.5G 25000 SL	K10104288175140	40	32	44	53	M16	160

SK 50 SFH03 080 AD+B/2.5G 25000 SL	K10105274131116	50	3	10	20	-	80
SK 50 SFH03 120 AD+B/2.5G 25000 SL	K10105274162116	50	3	10	20	-	120
SK 50 SFH03 160 AD+B/2.5G 25000 SL	K10105274175116	50	3	10	20	-	160
SK 50 SFH04 080 AD+B/2.5G 25000 SL	K10105275131116	50	4	15	22	-	80
SK 50 SFH04 120 AD+B/2.5G 25000 SL	K10105275162116	50	4	15	22	-	120
SK 50 SFH04 160 AD+B/2.5G 25000 SL	K10105275175116	50	4	15	22	-	160
SK 50 SFH05 080 AD+B/2.5G 25000 SL	K10105276131116	50	5	15	22	-	80
SK 50 SFH05 120 AD+B/2.5G 25000 SL	K10105276162116	50	5	15	22	-	120
SK 50 SFH05 160 AD+B/2.5G 25000 SL	K10105276175116	50	5	15	22	-	160
SK 50 SFH06 080 AD+B/2.5G 25000 SL	K10105277131116	50	6	21	27	M5	80
SK 50 SFH06 120 AD+B/2.5G 25000 SL	K10105277162116	50	6	21	27	M5	120
SK 50 SFH06 160 AD+B/2.5G 25000 SL	K10105277175116	50	6	21	27	M5	160
SK 50 SFH08 080 AD+B/2.5G 25000 SL	K10105285131116	50	8	21	27	M6	80
SK 50 SFH08 120 AD+B/2.5G 25000 SL	K10105285162116	50	8	21	27	M6	120
SK 50 SFH08 160 AD+B/2.5G 25000 SL	K10105285175116	50	8	21	27	M6	160
SK 50 SFH10 080 AD+B/2.5G 25000 SL	K10105279131116	50	10	24	31	M8	80
SK 50 SFH10 120 AD+B/2.5G 25000 SL	K10105279162116	50	10	24	31	M8	120
SK 50 SFH10 160 AD+B/2.5G 25000 SL	K10105279175116	50	10	24	31	M8	160
SK 50 SFH12 080 AD+B/2.5G 25000 SL	K10105280131116	50	12	24	31	M10	80
SK 50 SFH12 120 AD+B/2.5G 25000 SL	K10105280162116	50	12	24	31	M10	120
SK 50 SFH12 160 AD+B/2.5G 25000 SL	K10105280175116	50	12	24	31	M10	160

Note: All Dimensions are in mm

Continued...

Maximum Run out of the Internal Dia with respect to the External Taper 0.003 mm

SK (DIN 69871)
DIN ISO 7388 - 1
Holders

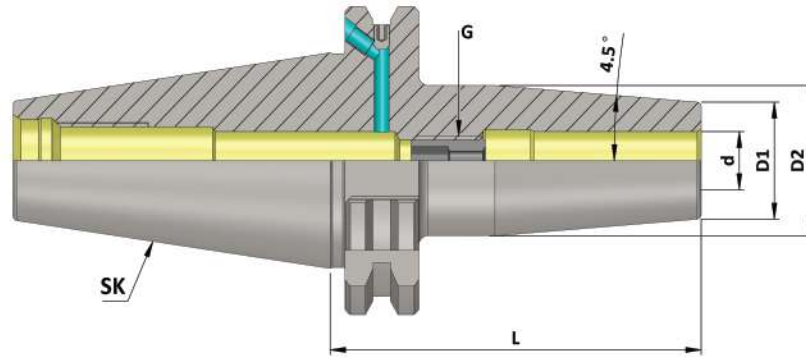

SK (DIN 69871) (SFH 4.5⁰) (AD+B) AD/AF

(Balanced to 2.5 G 25000 RPM)

Item Name	Item Code	SK	d	D1	D2	G	L
SK 50 SFH14 080 AD+B/2.5G 25000 SL	K10105284131116	50	14	27	34	M10	80
SK 50 SFH14 120 AD+B/2.5G 25000 SL	K10105284162116	50	14	27	34	M10	120
SK 50 SFH14 160 AD+B/2.5G 25000 SL	K10105284175116	50	14	27	34	M10	160
SK 50 SFH16 080 AD+B/2.5G 25000 SL	K10105281131116	50	16	27	34	M12	80
SK 50 SFH16 120 AD+B/2.5G 25000 SL	K10105281162116	50	16	27	34	M12	120
SK 50 SFH16 160 AD+B/2.5G 25000 SL	K10105281175116	50	16	27	34	M12	160
SK 50 SFH18 080 AD+B/2.5G 25000 SL	K10105282131116	50	18	33	40	M12	80
SK 50 SFH18 120 AD+B/2.5G 25000 SL	K10105282162116	50	18	33	40	M12	120
SK 50 SFH18 160 AD+B/2.5G 25000 SL	K10105282175116	50	18	33	40	M12	160
SK 50 SFH20 080 AD+B/2.5G 25000 SL	K10105283131116	50	20	33	40	M16	80
SK 50 SFH20 120 AD+B/2.5G 25000 SL	K10105283162116	50	20	33	40	M16	120
SK 50 SFH20 160 AD+B/2.5G 25000 SL	K10105283175116	50	20	33	40	M16	160
SK 50 SFH25 100 AD+B/2.5G 25000 SL	K10105287148116	50	25	44	53	M16	100
SK 50 SFH25 120 AD+B/2.5G 25000 SL	K10105287162116	50	25	44	53	M16	120
SK 50 SFH25 160 AD+B/2.5G 25000 SL	K10105287175116	50	25	44	53	M16	160
SK 50 SFH32 100 AD+B/2.5G 25000 SL	K10105288148116	50	32	44	53	M16	100
SK 50 SFH32 120 AD+B/2.5G 25000 SL	K10105288162116	50	32	44	53	M16	120
SK 50 SFH32 160 AD+B/2.5G 25000 SL	K10105288175116	50	32	44	53	M16	160

Note: All Dimensions are in mm

Maximum Run out of the Internal Dia with respect to the External Taper 0.003 mm

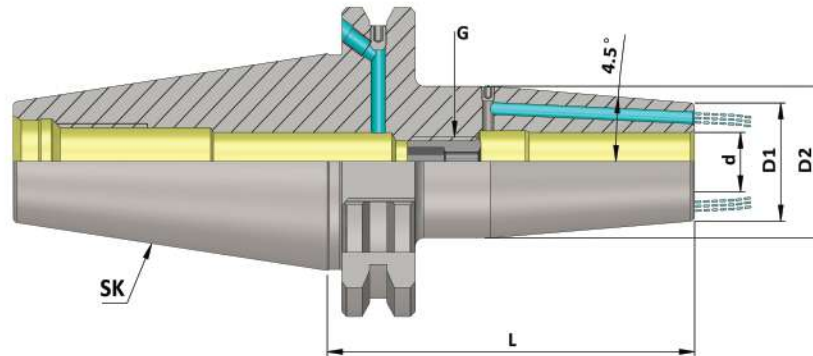

SK (DIN 69871) (SFH FCC 4.5°) (AD+B) AD/ AF

(Balanced to 2.5 G 25000 RPM)

Item Name	Item Code	SK	d	D1	D2	G	L
SK40 SFH03 080 FCC AD+B/2.5G 25000 SL	K10104274131255	40	3	10	20	-	80
SK40 SFH03 120 FCC AD+B/2.5G 25000 SL	K10104274162255	40	3	10	20	-	120
SK40 SFH03 160 FCC AD+B/2.5G 25000 SL	K10104274175255	40	3	10	20	-	160
SK40 SFH04 080 FCC AD+B/2.5G 25000 SL	K10104275131255	40	4	15	22	-	80
SK40 SFH04 120 FCC AD+B/2.5G 25000 SL	K10104275162255	40	4	15	22	-	120
SK40 SFH04 160 FCC AD+B/2.5G 25000 SL	K10104275175255	40	4	15	22	-	160
SK40 SFH05 080 FCC AD+B/2.5G 25000 SL	K10104276131255	40	5	15	22	-	80
SK40 SFH05 120 FCC AD+B/2.5G 25000 SL	K10104276162255	40	5	15	22	-	120
SK40 SFH05 160 FCC AD+B/2.5G 25000 SL	K10104276175255	40	5	15	22	-	160
SK40 SFH06 080 FCC AD+B/2.5G 25000 SL	K10104277131255	40	6	21	27	M5	80
SK40 SFH06 120 FCC AD+B/2.5G 25000 SL	K10104277162255	40	6	21	27	M5	120
SK40 SFH06 160 FCC AD+B/2.5G 25000 SL	K10104277175255	40	6	21	27	M5	160
SK40 SFH08 080 FCC AD+B/2.5G 25000 SL	K10104285131255	40	8	21	27	M6	80
SK40 SFH08 120 FCC AD+B/2.5G 25000 SL	K10104285162255	40	8	21	27	M6	120
SK40 SFH08 160 FCC AD+B/2.5G 25000 SL	K10104285175255	40	8	21	27	M6	160
SK40 SFH10 080 FCC AD+B/2.5G 25000 SL	K10104279131255	40	10	24	31	M8	80
SK40 SFH10 120 FCC AD+B/2.5G 25000 SL	K10104279162255	40	10	24	31	M8	120
SK40 SFH10 160 FCC AD+B/2.5G 25000 SL	K10104279175255	40	10	24	31	M8	160
SK40 SFH12 080 FCC AD+B/2.5G 25000 SL	K10104280131255	40	12	24	31	M10	80
SK40 SFH12 120 FCC AD+B/2.5G 25000 SL	K10104280162255	40	12	24	31	M10	120
SK40 SFH12 160 FCC AD+B/2.5G 25000 SL	K10104280175255	40	12	24	31	M10	160

Note: All Dimensions are in mm

Continued...

Maximum Run out of the Internal Dia with respect to the External Taper 0.003 mm

SK (DIN 69871)
DIN ISO 7388 - 1
Holders

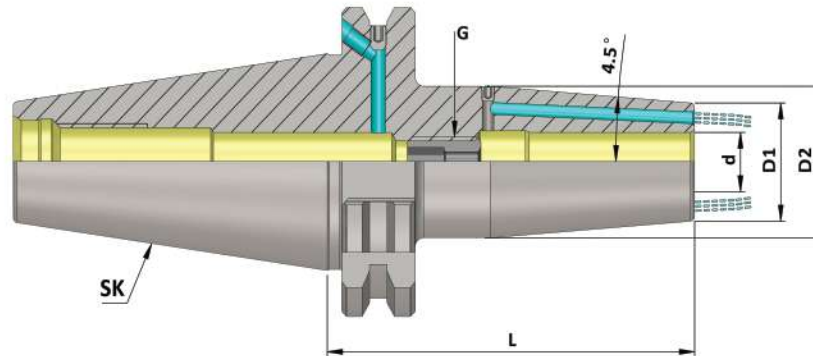

SK (DIN 69871) (SFH FCC 4.5°) (AD+B) AD/ AF

(Balanced to 2.5 G 25000 RPM)

Item Name	Item Code	SK	d	D1	D2	G	L
SK40 SFH14 080 FCC AD+B/2.5G 25000 SL	K10104284131255	40	14	27	34	M10	80
SK40 SFH14 120 FCC AD+B/2.5G 25000 SL	K10104284162255	40	14	27	34	M10	120
SK40 SFH14 160 FCC AD+B/2.5G 25000 SL	K10104284175255	40	14	27	34	M10	160
SK40 SFH16 080 FCC AD+B/2.5G 25000 SL	K10104281131255	40	16	27	34	M12	80
SK40 SFH16 120 FCC AD+B/2.5G 25000 SL	K10104281162255	40	16	27	34	M12	120
SK40 SFH16 160 FCC AD+B/2.5G 25000 SL	K10104281175255	40	16	27	34	M12	160
SK40 SFH18 080 FCC AD+B/2.5G 25000 SL	K10104282131255	40	18	33	40	M12	80
SK40 SFH18 120 FCC AD+B/2.5G 25000 SL	K10104282162255	40	18	33	40	M12	120
SK40 SFH18 160 FCC AD+B/2.5G 25000 SL	K10104282175255	40	18	33	40	M12	160
SK40 SFH20 080 FCC AD+B/2.5G 25000 SL	K10104283131255	40	20	33	40	M16	80
SK40 SFH20 120 FCC AD+B/2.5G 25000 SL	K10104283162255	40	20	33	40	M16	120
SK40 SFH20 160 FCC AD+B/2.5G 25000 SL	K10104283175255	40	20	33	40	M16	160
SK40 SFH25 100 FCC AD+B/2.5G 25000 SL	K10104287148255	40	25	44	53	M16	100
SK40 SFH25 120 FCC AD+B/2.5G 25000 SL	K10104287162255	40	25	44	53	M16	120
SK40 SFH25 160 FCC AD+B/2.5G 25000 SL	K10104287175255	40	25	44	53	M16	160
SK40 SFH32 100 FCC AD+B/2.5G 25000 SL	K10104288148255	40	32	44	53	M16	100
SK40 SFH32 120 FCC AD+B/2.5G 25000 SL	K10104288162255	40	32	44	53	M16	120
SK40 SFH32 160 FCC AD+B/2.5G 25000 SL	K10104288175255	40	32	44	53	M16	160

Note: All Dimensions are in mm

Maximum Run out of the Internal Dia with respect to the External Taper 0.003 mm

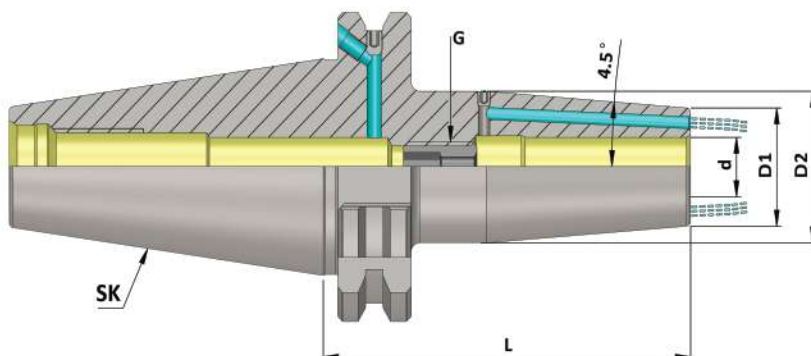

SK (DIN 69871)
DIN ISO 7388 - 1
Holders

SK (DIN 69871) (SFH FCC 4.5°) (AD+B) AD/ AF

(Balanced to 2.5 G 25000 RPM)

Item Name	Item Code	SK	d	D1	D2	G	L
SK50 SFH03 080 FCC AD+B/2.5G 25000 SL	K10105274131255	50	3	10	20	-	80
SK50 SFH03 120 FCC AD+B/2.5G 25000 SL	K10105274162255	50	3	10	20	-	120
SK50 SFH03 160 FCC AD+B/2.5G 25000 SL	K10105274175255	50	3	10	20	-	160
SK50 SFH04 080 FCC AD+B/2.5G 25000 SL	K10105275131255	50	4	15	22	-	80
SK50 SFH04 120 FCC AD+B/2.5G 25000 SL	K10105275162255	50	4	15	22	-	120
SK50 SFH04 160 FCC AD+B/2.5G 25000 SL	K10105275175255	50	4	15	22	-	160
SK50 SFH05 080 FCC AD+B/2.5G 25000 SL	K10105276131255	50	5	15	22	-	80
SK50 SFH05 120 FCC AD+B/2.5G 25000 SL	K10105276162255	50	5	15	22	-	120
SK50 SFH05 160 FCC AD+B/2.5G 25000 SL	K10105276175255	50	5	15	22	-	160
SK50 SFH06 080 FCC AD+B/2.5G 25000 SL	K10105277131255	50	6	21	27	M5	80
SK50 SFH06 120 FCC AD+B/2.5G 25000 SL	K10105277162255	50	6	21	27	M5	120
SK50 SFH06 160 FCC AD+B/2.5G 25000 SL	K10105277175255	50	6	21	27	M5	160
SK50 SFH08 080 FCC AD+B/2.5G 25000 SL	K10105285131255	50	8	21	27	M6	80
SK50 SFH08 120 FCC AD+B/2.5G 25000 SL	K10105285162255	50	8	21	27	M6	120
SK50 SFH08 160 FCC AD+B/2.5G 25000 SL	K10105285175255	50	8	21	27	M6	160
SK50 SFH10 080 FCC AD+B/2.5G 25000 SL	K10105279131255	50	10	24	31	M8	80
SK50 SFH10 120 FCC AD+B/2.5G 25000 SL	K10105279162255	50	10	24	31	M8	120
SK50 SFH10 160 FCC AD+B/2.5G 25000 SL	K10105279175255	50	10	24	31	M8	160
SK50 SFH12 080 FCC AD+B/2.5G 25000 SL	K10105280131255	50	12	24	31	M10	80
SK50 SFH12 120 FCC AD+B/2.5G 25000 SL	K10105280162255	50	12	24	31	M10	120
SK50 SFH12 160 FCC AD+B/2.5G 25000 SL	K10105280175255	50	12	24	31	M10	160

Note: All Dimensions are in mm

Continued...

Maximum Run out of the Internal Dia with respect to the External Taper 0.003 mm

SK (DIN 69871)
DIN ISO 7388 - 1
Holders

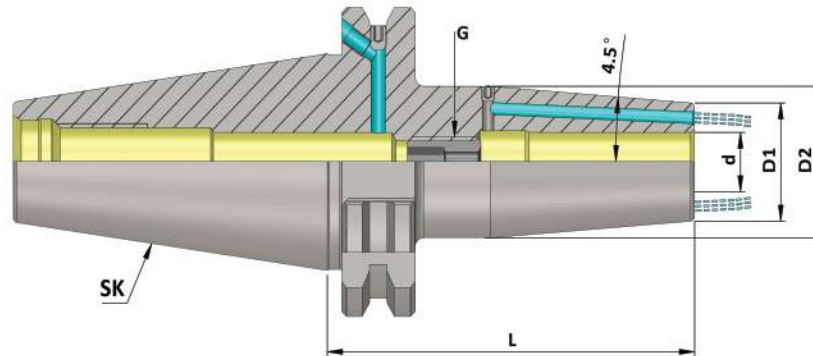

SK (DIN 69871) (SFH FCC 4.5°) (AD+B) AD/ AF

(Balanced to 2.5 G 25000 RPM)

Item Name	Item Code	SK	d	D1	D2	G	L
SK50 SFH14 080 FCC AD+B/2.5G 25000 SL	K10105284131255	50	14	27	34	M10	80
SK50 SFH14 120 FCC AD+B/2.5G 25000 SL	K10105284162255	50	14	27	34	M10	120
SK50 SFH14 160 FCC AD+B/2.5G 25000 SL	K10105284175255	50	14	27	34	M10	160
SK50 SFH16 080 FCC AD+B/2.5G 25000 SL	K10105281131255	50	16	27	34	M12	80
SK50 SFH16 120 FCC AD+B/2.5G 25000 SL	K10105281162255	50	16	27	34	M12	120
SK50 SFH16 160 FCC AD+B/2.5G 25000 SL	K10105281175255	50	16	27	34	M12	160
SK50 SFH18 080 FCC AD+B/2.5G 25000 SL	K10105282131255	50	18	33	40	M12	80
SK50 SFH18 120 FCC AD+B/2.5G 25000 SL	K10105282162255	50	18	33	40	M12	120
SK50 SFH18 160 FCC AD+B/2.5G 25000 SL	K10105282175255	50	18	33	40	M12	160
SK50 SFH20 080 FCC AD+B/2.5G 25000 SL	K10105283131255	50	20	33	40	M16	80
SK50 SFH20 120 FCC AD+B/2.5G 25000 SL	K10105283162255	50	20	33	40	M16	120
SK50 SFH20 160 FCC AD+B/2.5G 25000 SL	K10105283175255	50	20	33	40	M16	160
SK50 SFH25 100 FCC AD+B/2.5G 25000 SL	K10105287148255	50	25	44	53	M16	100
SK50 SFH25 120 FCC AD+B/2.5G 25000 SL	K10105287162255	50	25	44	53	M16	120
SK50 SFH25 160 FCC AD+B/2.5G 25000 SL	K10105287175255	50	25	44	53	M16	160
SK50 SFH32 100 FCC AD+B/2.5G 25000 SL	K10105288148255	50	32	44	53	M16	100
SK50 SFH32 120 FCC AD+B/2.5G 25000 SL	K10105288162255	50	32	44	53	M16	120
SK50 SFH32 160 FCC AD+B/2.5G 25000 SL	K10105288175255	50	32	44	53	M16	160

Note: All Dimensions are in mm

Maximum Run out of the Internal Dia with respect to the External Taper 0.003 mm

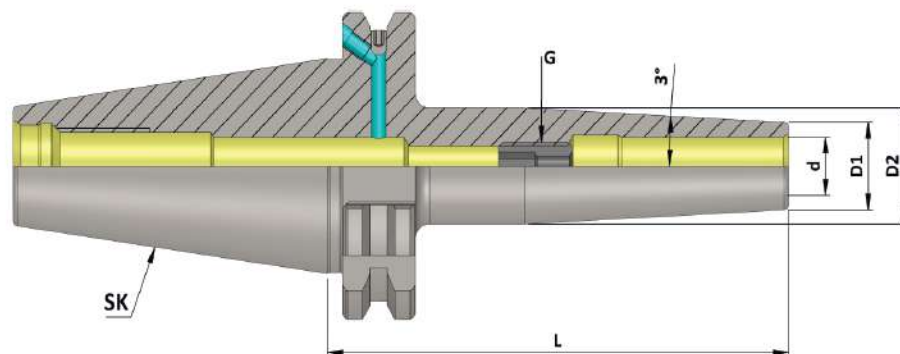

SK (DIN 69871)
DIN ISO 7388 - 1
Holders

SK (DIN-69871) (SFH SLIM 3°) (AD+B) AD/ AF

(Balanced to 2.5 G 25000 RPM)

Item Name	Item Code	SK	d	D1	D2	G	L
SK40 SFH03 080 SLIM AD+B/2.5G 25000 SL	K10104274131259	40	3	9	14	-	80
SK40 SFH03 120 SLIM AD+B/2.5G 25000 SL	K10104274162259	40	3	9	18	-	120
SK40 SFH03 160 SLIM AD+B/2.5G 25000 SL	K10104274175259	40	3	9	19	-	160
SK40 SFH04 080 SLIM AD+B/2.5G 25000 SL	K10104275131259	40	4	10	15	-	80
SK40 SFH04 120 SLIM AD+B/2.5G 25000 SL	K10104275162259	40	4	10	19	-	120
SK40 SFH04 160 SLIM AD+B/2.5G 25000 SL	K10104275175259	40	4	10	20	-	160
SK40 SFH05 080 SLIM AD+B/2.5G 25000 SL	K10104276131259	40	5	11	16	-	80
SK40 SFH05 120 SLIM AD+B/2.5G 25000 SL	K10104276162259	40	5	11	20	-	120
SK40 SFH05 160 SLIM AD+B/2.5G 25000 SL	K10104276175259	40	5	11	21	-	160
SK40 SFH06 080 SLIM AD+B/2.5G 25000 SL	K10104277131259	40	6	12	17	M5	80
SK40 SFH06 120 SLIM AD+B/2.5G 25000 SL	K10104277162259	40	6	12	21	M5	120
SK40 SFH06 160 SLIM AD+B/2.5G 25000 SL	K10104277175259	40	6	12	25	M5	160
SK40 SFH08 080 SLIM AD+B/2.5G 25000 SL	K10104285131259	40	8	14	19	M6	80
SK40 SFH08 120 SLIM AD+B/2.5G 25000 SL	K10104285162259	40	8	14	23	M6	120
SK40 SFH08 160 SLIM AD+B/2.5G 25000 SL	K10104285175259	40	8	14	27	M6	160
SK40 SFH10 080 SLIM AD+B/2.5G 25000 SL	K10104279131259	40	10	16	21	M8	80
SK40 SFH10 120 SLIM AD+B/2.5G 25000 SL	K10104279162259	40	10	16	25	M8	120
SK40 SFH10 160 SLIM AD+B/2.5G 25000 SL	K10104279175259	40	10	16	29	M8	160
SK40 SFH12 080 SLIM AD+B/2.5G 25000 SL	K10104280139259	40	12	18	23	M10	80
SK40 SFH12 120 SLIM AD+B/2.5G 25000 SL	K10104280162259	40	12	18	27	M10	120
SK40 SFH12 160 SLIM AD+B/2.5G 25000 SL	K10104280175259	40	12	18	31	M10	160
SK40 SFH14 080 SLIM AD+B/2.5G 25000 SL	K10104284131259	40	14	20	26	M10	80
SK40 SFH14 120 SLIM AD+B/2.5G 25000 SL	K10104284162259	40	14	20	29	M10	120
SK40 SFH14 160 SLIM AD+B/2.5G 25000 SL	K10104284175259	40	14	20	32	M10	160
SK40 SFH16 080 SLIM AD+B/2.5G 25000 SL	K10104281131259	40	16	22	28	M12	80
SK40 SFH16 120 SLIM AD+B/2.5G 25000 SL	K10104281162259	40	16	22	31	M12	120
SK40 SFH16 160 SLIM AD+B/2.5G 25000 SL	K10104281175259	40	16	22	34	M12	160
SK40 SFH18 080 SLIM AD+B/2.5G 25000 SL	K10104282131259	40	18	24	30	M12	80
SK40 SFH18 120 SLIM AD+B/2.5G 25000 SL	K10104282162259	40	18	24	33	M12	120
SK40 SFH18 160 SLIM AD+B/2.5G 25000 SL	K10104282175259	40	18	24	36	M12	160
SK40 SFH20 080 SLIM AD+B/2.5G 25000 SL	K10104283131259	40	20	26	32	M16	80
SK40 SFH20 120 SLIM AD+B/2.5G 25000 SL	K10104283162259	40	20	26	35	M16	120
SK40 SFH20 160 SLIM AD+B/2.5G 25000 SL	K10104283175259	40	20	26	38	M16	160

Note: All Dimensions are in mm

Maximum Run out of the Internal Dia with respect to the External Taper 0.003 mm

SK (DIN 69871)
 DIN ISO 7388 - 1
 Holders

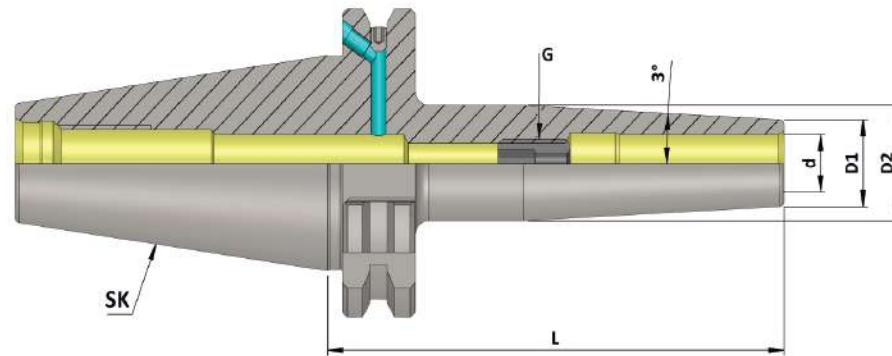

SK (DIN-69871) (SFH SLIM 3°) (AD+B) AD/ AF

(Balanced to 2.5 G 25000 RPM)

Item Name	Item Code	SK	d	D1	D2	G	L
SK50 SFH03 080 SLIM AD+B/2.5G 25000 SL	K10105274131259	50	3	9	14	-	80
SK50 SFH03 120 SLIM AD+B/2.5G 25000 SL	K10105274162259	50	3	9	18	-	120
SK50 SFH04 080 SLIM AD+B/2.5G 25000 SL	K10105275131259	50	4	10	15	-	80
SK50 SFH04 120 SLIM AD+B/2.5G 25000 SL	K10105275162259	50	4	10	19	-	120
SK50 SFH05 080 SLIM AD+B/2.5G 25000 SL	K10105276131259	50	5	11	16	-	80
SK50 SFH05 120 SLIM AD+B/2.5G 25000 SL	K10105276162259	50	5	11	20	-	120
SK50 SFH06 080 SLIM AD+B/2.5G 25000 SL	K10105277131259	50	6	12	17	M5	80
SK50 SFH06 120 SLIM AD+B/2.5G 25000 SL	K10105277162259	50	6	12	21	M5	120
SK50 SFH06 160 SLIM AD+B/2.5G 25000SL	K10105277175259	50	6	12	25	M5	160
SK50 SFH08 080 SLIM AD+B/2.5G 25000 SL	K10105285131259	50	8	14	19	M6	80
SK50 SFH08 120 SLIM AD+B/2.5G 25000 SL	K10105285162259	50	8	14	23	M6	120
SK50 SFH08 160 SLIM AD+B/2.5G 25000SL	K10105285175259	50	8	14	27	M6	160
SK50 SFH10 080 SLIM AD+B/2.5G 25000 SL	K10105279131259	50	10	16	21	M8	80
SK50 SFH10 120 SLIM AD+B/2.5G 25000 SL	K10105279162259	50	10	16	25	M8	120
SK50 SFH10 160 SLIM AD+B/2.5G 25000 SL	K10105279175259	50	10	16	29	M8	160
SK50 SFH12 080 SLIM AD+B/2.5G 25000 SL	K10105280131259	50	12	18	23	M10	80
SK50 SFH12 120 SLIM AD+B/2.5G 25000 SL	K10105280162259	50	12	18	27	M10	120
SK50 SFH12 160 SLIM AD+B/2.5G 25000SL	K10105280175259	50	12	18	31	M10	160
SK50 SFH14 080 SLIM AD+B/2.5G 25000SL	K10105284148259	50	14	20	26	M10	80
SK50 SFH14 120 SLIM AD+B/2.5G 25000SL	K10105284162259	50	14	20	29	M10	120
SK50 SFH14 160 SLIM AD+B/2.5G 25000 SL	K10105284175259	50	14	20	32	M10	160
SK50 SFH16 080 SLIM AD+B/2.5G 25000 SL	K10105281131259	50	16	22	28	M12	80
SK50 SFH16 120 SLIM AD+B/2.5G 25000 SL	K10105281162259	50	16	22	31	M12	120
SK50 SFH16 160 SLIM AD+B/2.5G 25000 SL	K10105281175259	50	16	22	34	M12	160
SK50 SFH18 080 SLIM AD+B/2.5G 25000 SL	K10105282131259	50	18	24	30	M12	80
SK50 SFH18 120 SLIM AD+B/2.5G 25000 SL	K10105282148259	50	18	24	33	M12	120
SK50 SFH18 160 SLIM AD+B/2.5G 25000 SL	K10105282175259	50	18	24	36	M12	160
Sk50 SFH20 080 SLIM AD+B/2.5G 25000 SL	K10105283131259	50	20	26	32	M16	80
Sk50 SFH20 120 SLIM AD+B/2.5G 25000 SL	K10105283148259	50	20	26	35	M16	120
SK50 SFH20 160 SLIM AD+B/2.5G 25000SL	K10105283175259	50	20	26	38	M16	160

Note: All Dimensions are in mm

Maximum Run out of the Internal Dia with respect to the External Taper 0.005 mm

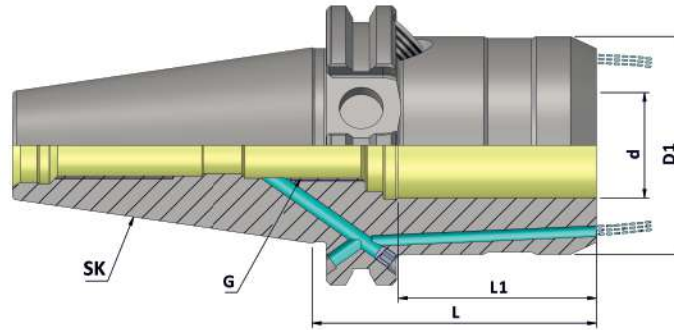

SK (DIN 69871)
DIN ISO 7388 - 1
Holders

SK (DIN 69871) (HC) (FCC) (AD+B) AD/ AF

(Balanced to 2.5 G 25000 RPM)

Item Name	Item Code	SK	d	D1	G	L	L1
SK40 HC12S 050 FCC AD+B/2.5G 25000 SL	K10104629131230	40	12	42	M10X1	50	40
SK40 HC20S 64.5 FCC AD+B/2.5G25000 SL	K10104168122140	40	20	50	M16X1	64.5	42
SK50 HC12S 50.5 FCC AD+B/2.5G25000 SL	K10105629338255	50	12	42	M10X1	50.5	40
SK50 HC20S 64.5 FCC AD+B/2.5G 25000 SL	K10105168122230	50	20	50	M16X1	64.5	42
SK50 HC32S 81.0 FCC AD+B/2.5G25000 SL	K10105272140140	50	32	72	M16X1	81	55

Accessories:



Reduction Sleeve (RS)
Ref. Page No. 242

Note: All Dimensions are in mm

◆ Features:

- KTA "Minimum Length Compensation Tapping Chuck (MLC)" For Synchronised (Rigid) Tapping Cycle.
- Best suitable for Die & Mould Industry.
- Compression & Expansion +/- 0.5mm
- High Concentricity Enables High Speed Tapping.
- Positive Clamping Through ER Tap Collet.

◆ Technical Details :

- "MLC" Tapping Chucks to be used with CNC Machines, having Synchronised Tapping cycle.
- In this case, Rigid Tapping cycle takes care of tap pitch controlling the feed, spindle speed and feed. So, theoretically, ordinary holder without any compensation also should be suitable for performing the process.
- ◆ But by law of theory, following factors they do affect tapping quality, tap life etc.
 1. Dynamics of machine
 2. Synchronisation of spindle speed & feed.
 3. During Change of Spindle, Rotational direction and feed direction.
 4. Pitch error on Tap / Tolerance on Pitch

◆ This will lead to :

1. Less Tap life because of Flank wear (one side)
 2. Damaged Flanks on threads on the work piece
 3. Threads not answering to Gauge.
- ◆ All above errors can be taken care by using ' MLC '
 - ◆ KTA 'MLC' Tapping Chucks with +/- 0.5 mm compensation.

◆ Available In Following Range :

- ER 16 : M3 to M12
- ER 20 : M3 to M16
- ER 25 : M3 to M20
- ER 32 : M4 to M27
- ER 40 : M6 to M33

◆ Available In Mountings :

- BT (MAS 403) (DIN ISO 7388-2)
- BBT (MAS 403)
- SK (DIN 69871) (DIN ISO 7388-1)
- HSK- A (DIN 69893-1)
- CAT (ANSI B 5.50)
- Cylindrical Shank

◆ Balancing :

- Main Body Balanced to 2.5G 25000 RPM



Maximum Run out of the Internal Taper with respect to the External Taper 0.020 mm

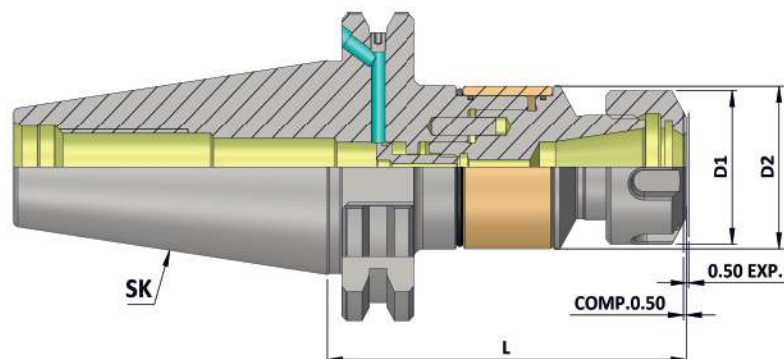

SK (DIN 69871)
DIN ISO 7388 - 1
Holders

SK (DIN 69871) (MLC)

Item Name	Item Code	SK	Capacity	Clamping Range	Nut Size	D1	D2	L	Comp.	Exp.
SK 40 ER 16M 079 AD+B MLC	K10104157551245	40	M3-M12	1-10	ER 16M	22	34	79	0.5	0.5
SK 40 ER 16 079 AD+B MLC	K10104149551245	40	M3-M12	1-10	ER 16	32	34	79	0.5	0.5
SK 40 ER 20 080 AD+B MLC	K10104150131250	40	M3-M16	3.5-10	ER 20	35	34	80	0.5	0.5
SK 40 ER 25 084 AD+B MLC	K10104151134245	40	M3-M20	3.5-16	ER 25	42	34	84	0.5	0.5
SK 40 ER 32 095 AD+B MLC	K10104152145245	40	M4-M27	3.5-20	ER 32	50	45	95	0.5	0.5
SK 40 ER 40 120 AD+B MLC	K10104153162245	40	M6-M33	6-26	ER 40	63	62	120	0.5	0.5

SK 50 ER 16M 079 AD+B MLC	K10105157551250	50	M3-M12	1-10	ER 16M	22	34	79	0.5	0.5
SK 50 ER 16 079 AD+B MLC	K10105149551245	50	M3-M12	1-10	ER 16	32	34	79	0.5	0.5
SK 50 ER 20 080 AD+B MLC	K10105150131250	50	M3-M16	3.5-10	ER 20	35	34	80	0.5	0.5
SK 50 ER 25 084 AD+B MLC	K10105151134245	50	M3-M20	3.5-16	ER 25	42	34	84	0.5	0.5
SK 50 ER 32 095 AD+B MLC	K10105152145245	50	M4-M27	3.5-20	ER 32	50	45	95	0.5	0.5
SK 50 ER 40 105 AD+B MLC	K10105153152245	50	M6-M33	6-26	ER 40	63	62	105	0.5	0.5

Accessories:



Tap Collet ER G
Ref. Page No. 238-240



Q.C.Tap Collet QCTC
Ref. Page No. 243-251



ER Nut
Ref. Page No. 220-221

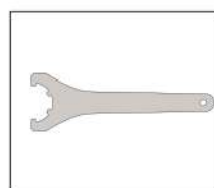

Spanner
Ref. Page No. 222

Note: All Dimensions are in mm



Quick Change Tapping Chuck (KWFLK)

KWFLK For CNC Machines

◆ **Application :**

- Most Suitable Tapping Chuck for CNC Machines, Manual Drilling Machines, Lathe Machines & Milling machines.

◆ **Features:**

- Quick Change feature to suit KTA - Quick Change Adaptors with and without safety clutch.
- Length compensation to compensate difference in pitch between positive feed and the pitch of the tap.
- The chuck is equipped with an adjustable device to increase the cutting pressure to ensure positive start when tapping cycle commences.
- Chucks WFLK can be applied horizontal or vertical and are used for right or left hand threads.

◆ **Available In Mountings :**

- BT (MAS 403) (DIN ISO 7388 - 2)
- BBT (MAS 403)
- SK (DIN 69871) (DIN ISO 7388 - 1)
- HSK-A (DIN 69893-1)
- CAT (ANSI B 5.50)
- HSK-F (DIN 6989-1)
- Cylindrical Shank
- Morse Taper Shank

◆ **Available In Sizes :**

- KWFLK1
- KWFLK2
- KWFLK3
- KWFLK4



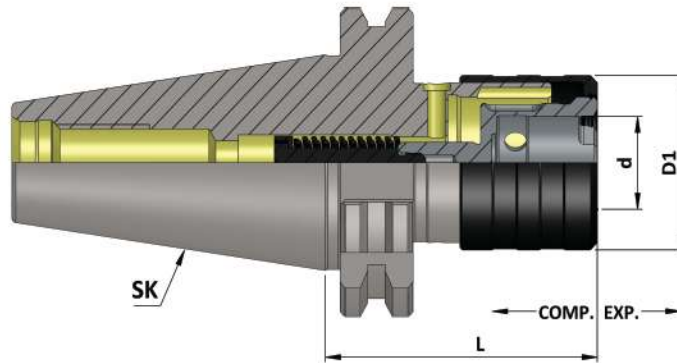

SK (DIN 69871) (KWFLK)

Item Name	Item Code	SK	Capacity	Suitable Adaptor	Comp.	Exp.	d	D1	L
SK 30 KWFLK1 64.0	K10194169278127	30	M3-M12	KWES1B	7.50	7.50	19	36	64
SK 40 KWFLK1 60.0	K10104169287127	40	M3-M12	KWES1B	7.50	7.50	19	36	60
SK 40 KWFLK2 98.0	K10104170288127	40	M8-M20	KWES2B	12.50	12.50	31	53	98
SK 40 KWFLK3 150.0	K10104171289127	40	M14-M33	KWES3B	20.00	20.00	48	78	150
SK 40 KWFLK4 164.5	K10104172176127	40	M22-M48	KWES4B	22.50	22.50	60	96	164.5
SK 50 KWFLK1 60.0	K10105169287127	50	M3-M12	KWES1B	7.50	7.50	19	36	60
SK 50 KWFLK2 84.0	K10105170290127	50	M8-M20	KWES2B	12.50	12.50	31	53	84
SK 50 KWFLK3 139.0	K10105171291127	50	M14-M33	KWES3B	20.00	20.00	48	78	139
SK 50 KWFLK4 152.0	K10105172292127	50	M22-M48	KWES4B	22.50	22.50	60	96	152

Accessories:

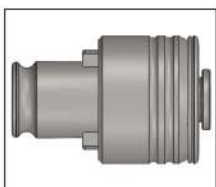

Tap Adaptor KWES..B & KWESK..B
 Ref. Page No. 260-279



Tap Adaptor
 Reduction Socket KWRE
 Ref. Page No. 280

Note: • All Dimensions are in mm
 • For Tap Shank Dimension & Recommended Torque Values Ref. Page No. 281-284